

# LMV243

## Single-Channel, Quad-Band GSM Power Controller in micro SMD

### General Description

The device is intended for use within an RF transmit power control loop in GSM mobile phones and supports GaAs HBT and bipolar RF single supply power amplifiers. The circuit operates with a single supply from 2.7V to 3.3V.

The LMV243 contains an RF detector, error amplifier, ramp V/I converter and output driver. The LMV243 input interface consists of the RF input, Ramp voltage, and a digital input to perform the function 'Shutdown/Transmit Enable'. The device will be active in the case TX\_EN = HI, otherwise, the device goes into a low power consumption shutdown mode. During shutdown the output will be in high impedance (tri-state).

A single external RC combination is used to provide stable operations that accommodates individual PA characteristics. The LMV243 is offered in a 8-bump micro SMD 1.5mm x 1.5mm package. This space savings package supports flexible product placement almost anywhere in the circuitboard.

### Features

(Typical Unless Otherwise Noted)

- 50dB RF detection range (typical)
- micro SMD package 1.5mm x 1.5mm x 0.995mm
- Support of GaAs HBT, bipolar technology
- Quad-band operation
- Shutdown mode for Power Save in Rx slot
- GPRS compliant
- External loop compensation option
- Accurate temperature compensation
- Frequency range is 450MHz to 2GHz

### Applications

- GSM mobile phone
- AGC for digital audio
- TDMA RF control
- Wireless LAN

### Typical Application

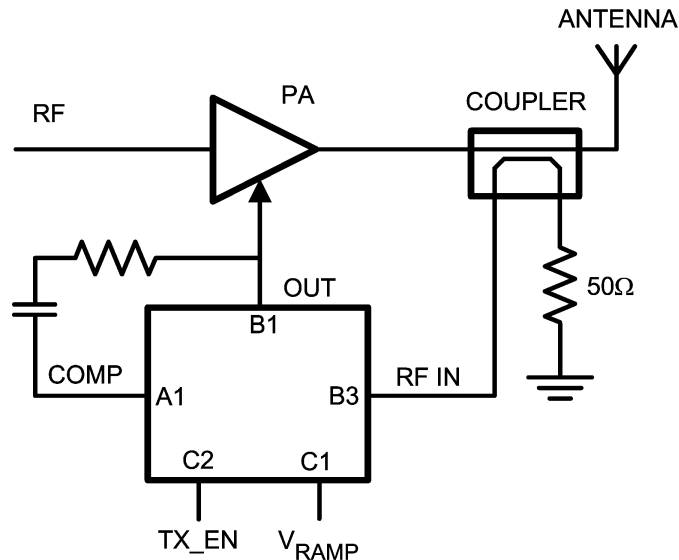

20029034

**Absolute Maximum Ratings** (Note 1)

If Military/Aerospace specified devices are required, please contact the National Semiconductor Sales Office/Distributors for availability and specifications.

Supply Voltage	
$V_{DD} - GND$	4V Max
ESD Tolerance (Note 2)	
Human Body Model	2000V
Machine Model	200V
Storage Temperature Range	-65°C to 150°C
Junction Temperature (Note 6)	150°C Max

Mounting Temperature

Infrared or convection (20 sec)

235°C

**Operating Ratings** (Note 1)

Nominal Supply Voltage	2.7V to 3.3V
Temperature Range	-40°C < $T_J$ < 85°C
$V_{RAMP}$ Voltage Range	0V to 2V
$V_{HOME}$ Voltage Range	0V to 2V
RF Frequency Range	450MHz to 2GHz

**Electrical Characteristics**

Unless otherwise specified, all limits are guaranteed to  $T_J = 25^\circ\text{C}$ .  $V_{DD} = 2.8\text{V}$ . **Boldface** limits apply at temperature extremes.

Symbol	Parameter	Condition	Min	Typ	Max	Units
$I_{DD}$	Supply Current	$V_{OUT} = (V_{DD} - GND)/2$		8.7	10.5	mA
		In Shutdown ( $TX\_EN = 0.8\text{V}$ ) $V_{OUT} = (V_{DD} - GND)/2$		4.6	<b>30</b>	
$V_{HIGH}$	Logic Level to Enable Power	(Note 7)	1.8			V
$V_{LOW}$	Logic Level to Disable Power	(Note 7)			0.8	V
$T_{ON}$	Turn-on- Time from Shutdown			3.7	6.5	$\mu\text{s}$
					<b>7.5</b>	
$I_{EN}$	Current into $TX\_EN$ Pin			0.108	<b>5</b>	$\mu\text{A}$
<b>RAMP Amplifier</b>						
$V_{RD}$	$V_{RAMP}$ Deadband		170	210	250	mV
			<b>150</b>		<b>270</b>	
$1/R_{RAMP}$	Transconductance	(Note 8)		78		$\mu\text{A}/\text{V}$
$I_{OUT\ RAMP}$	Ramp Amplifier Output Current	$V_{RAMP} = 2\text{V}$	<b>100</b>	140		$\mu\text{A}$
<b>RF Input</b>						
$P_{IN}$	RF Input Power Range (Note 5)	20k $\Omega$ // 27pF between $V_{OUT}$ and $V_{COMP}$		-50		dBm
				+5		
				-63		dBV
				-7		
	Logarithmic Slope (Note 9)	@ 900MHz, 20k $\Omega$ // 27pF between $V_{OUT}$ and $V_{COMP}$		-1.79		$\mu\text{A}/\text{dB}$
		@ 1800MHz, 20k $\Omega$ // 27pF between $V_{OUT}$ and $V_{COMP}$		-1.89		
		@ 1900MHz, 20k $\Omega$ // 27pF between $V_{OUT}$ and $V_{COMP}$		-1.89		
	Logarithmic Intercept (Note 9)	@ 900MHz, 20k $\Omega$ // 27pF between $V_{OUT}$ and $V_{COMP}$		-50.5		dBm
		@ 1800MHz, 20k $\Omega$ // 27pF between $V_{OUT}$ and $V_{COMP}$		-46.9		
		@ 1900MHz, 20k $\Omega$ // 27pF between $V_{OUT}$ and $V_{COMP}$		-45.9		
$R_{IN}$	DC Resistance	(Note 8)		50		$\Omega$
$C_{IN}$	Input Capacitance	(Note 8)		0.5		pF
<b>Error Amplifier</b>						
GBW	Gain-Bandwidth Product	(Note 8)		7.6		MHz

**Electrical Characteristics** Unless otherwise specified, all limits are guaranteed to  $T_J = 25^\circ\text{C}$ .  $V_{DD} = 2.8\text{V}$ .  
**Boldface** limits apply at temperature extremes. (Continued)

Symbol	Parameter	Condition	Min	Typ	Max	Units
$V_O$	Output Swing from Rail	Sourcing, $I_O = 5\text{mA}$		55	85 <b>105</b>	mV
		Sinking, $I_O = -5\text{mA}$		45	75 <b>95</b>	
$I_O$	Output Short Circuit Current (Note 3)	Sourcing, $V_O = 0\text{V}$	<b>25</b>	145		mA
		Sinking, $V_O = 2.8\text{V}$	<b>25</b>	180		
$e_n$	Output Referred Noise	RF input = 1800 MHz, -10dBm, 20k $\Omega$ // 27pF between $V_{OUT}$ and $V_{COMP}$ , $V_{OUT} = 1.4\text{V}$ , set by $V_{RAMP}$ , (Note 8)		700		nV/ $\sqrt{\text{Hz}}$
SR	Slew Rate		8 <b>5</b>	11		V/ $\mu\text{s}$

**Note 1:** Absolute Maximum Ratings indicate limits beyond which damage to the device may occur. Operating Ratings indicate conditions for which the device is intended to be functional, but specific performance is not guaranteed. For guaranteed specifications and the test conditions, see the Electrical Characteristics.

**Note 2:** Human body model: 1.5k $\Omega$  in series with 100pF. Machine model, 0 $\Omega$  in series with 100pF.

**Note 3:** Shorting circuit output to either  $V^+$  or  $V^-$  will adversely affect reliability.

**Note 4:** Electrical Table values apply only for factory testing conditions at the temperature indicated. Factory testing conditions result in very limited self-heating of the device such that  $T_J = T_A$ . No guarantee of parametric performance is indicated in the electrical tables under conditions of internal self-heating where  $T_J > T_A$ .

**Note 5:** Power in dBV = dBm + 13 when the impedance is 50 $\Omega$ .

**Note 6:** The maximum power dissipation is a function of  $T_{J(\text{MAX})}$ ,  $\theta_{JA}$  and  $T_A$ . The maximum allowable power dissipation at any ambient temperature is  $P_D = (T_{J(\text{MAX})} - T_A)/\theta_{JA}$ . All numbers apply for packages soldered directly into a PC board.

**Note 7:** All limits are guaranteed by design or statistical analysis.

**Note 8:** Typical values represent the most likely parametric norm.

**Note 9:** Slope and intercept are calculated from graphs ' $V_{OUT}$  vs. RF input Power' where the current is obtained by division of the voltage by 20k $\Omega$ .

## Connection Diagram

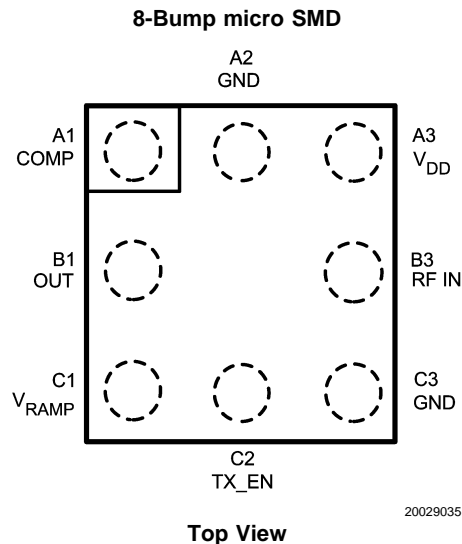

## Pin Descriptions

	Pin	Name	Description
Power Supply	A3	$V_{DD}$	Supply Voltage
	A2, C3	GND	Power Ground. Operation requires both pins be grounded.
Digital Inputs	C2	TX_EN	A Logic High to enable device.
Analog Inputs	B3	RF IN	RF Input connected to the Coupler output with optional attenuation to measure the Power Amplifier (PA) / Antenna RF power levels.
	C1	RAMP IN	Sets the RF output power level. The useful input voltage range is from 0.2V to 1.8V, although voltages from 0V to $V_{DD}$ are allowed.
Compensation	A1	Comp	Connects an external RC network between the Comp pin and the Output pin for an overall loop compensation and to control the closed loop frequency response. Conventional loop stability techniques can be used in selecting this network, such as Bode plots. A good starting value for the RC combination will be $C = 68\text{pF}$ and $R = 0\Omega$ .
Output	B1	Out	A rail-to-rail output capable of sourcing 25mA and sinking 25mA, with less than 200mV total voltage drop over the specified temperature. The output is free from glitches when enabled by TX_EN. When TX_EN is low, the output voltage is near GND.

- Note:** 1. All inputs and outputs are referenced to GND (pin A2, C3).  
 2. For the digital inputs, a LOW is  $< 0.8\text{V}$  and a HIGH is  $> 1.8\text{V}$ .  
 3. RF power detection is performed internally in the LMV243 and only an RF power coupler with optional extra attenuation has to be used.

## Ordering Information

Package	Part Number	Package Marking	Transport Media	NSC Drawing
8-Bump micro SMD	LMV243BL	01	1k Units Tape and Reel	BLA08AAC
	LMV243BLX	01	3k Units tape and Reel	

## Block Diagram

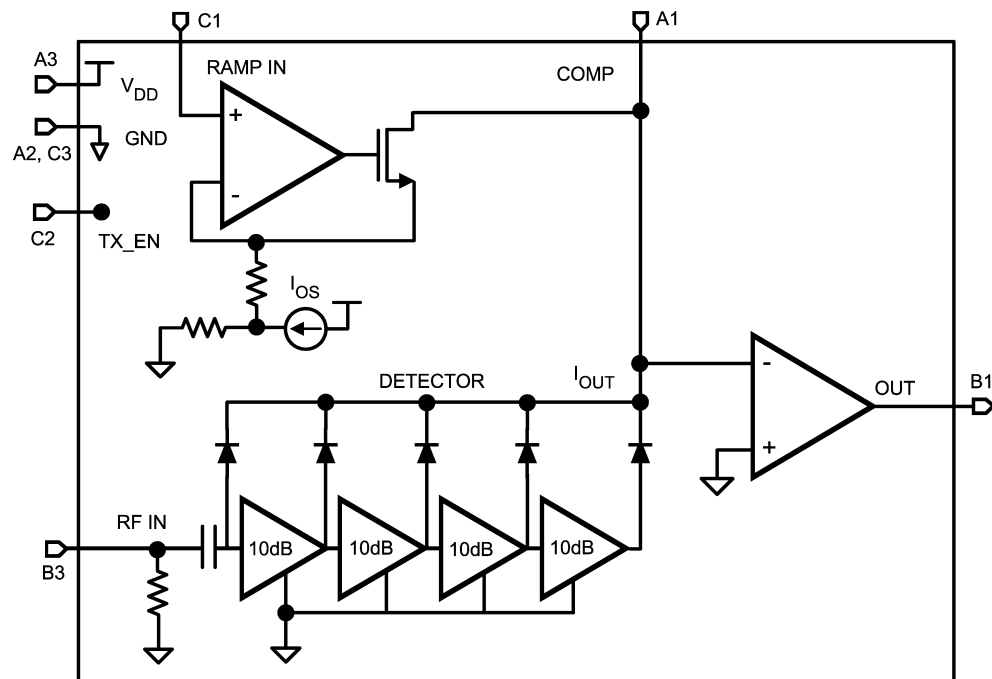

20029036

FIGURE 1.

# Typical Performance Characteristics

Unless otherwise specified,  $V_{DD} = +2.8V$ ,  $T_J = 25^\circ C$ .

Supply Current vs. Supply Voltage

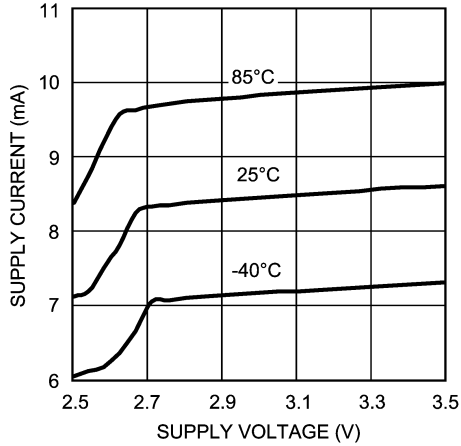

20029024

$V_{OUT}$  and Log Conformance vs. RF Input Power

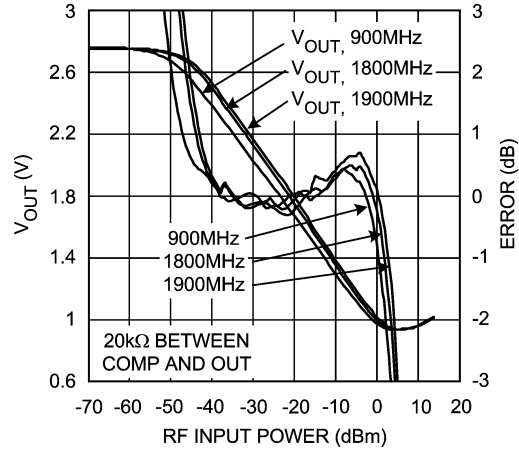

20029001

$V_{OUT}$  and Log Conformance vs. RF Input Power at Corners of GSM

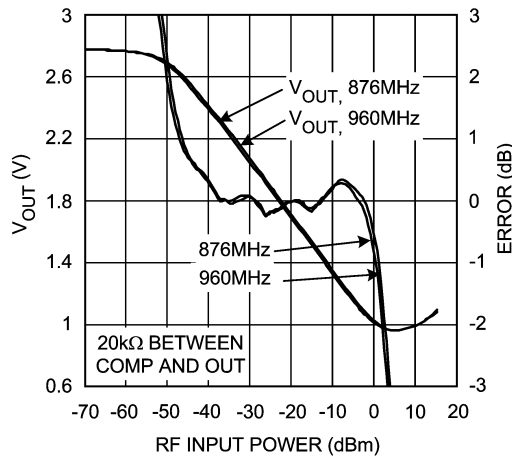

20029002

$V_{OUT}$  and Log Conformance vs. RF Input Power at Corners of DCS

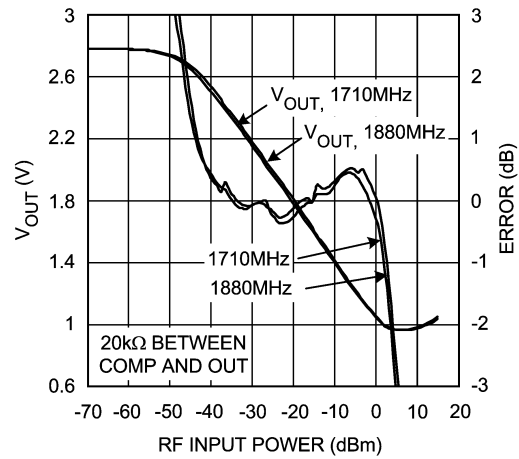

20029008

$V_{OUT}$  and Log Conformance vs. Pin @ Corners of PCS

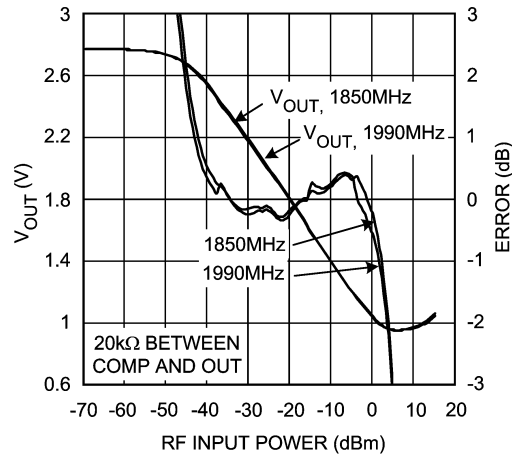

20029009

$V_{OUT}$  and Log Conformance vs. RF Input Power at 900MHz

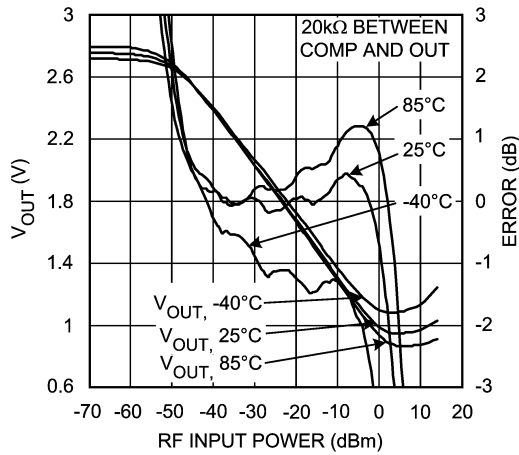

20029003

**Typical Performance Characteristics** Unless otherwise specified,  $V_{DD} = +2.8V$ ,  $T_J = 25^\circ C$ . (Continued)

**$V_{OUT}$  and Log Conformance vs. RF Input Power at 1800MHz**

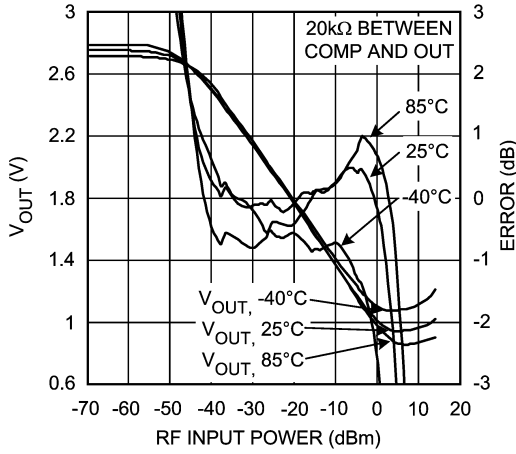

20029004

**$V_{OUT}$  and Log Conformance vs. RF Input Power at 1900MHz**

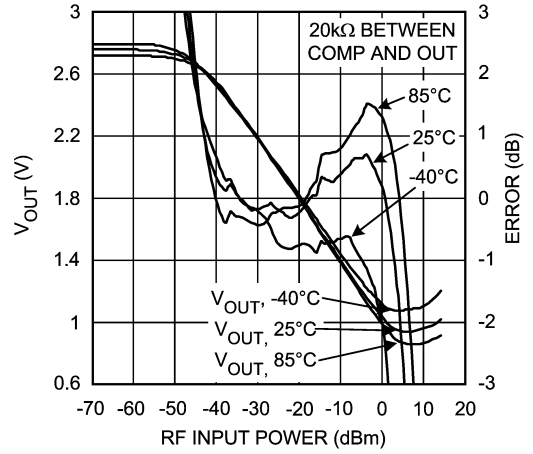

20029005

**Logarithmic Slope vs. Frequency**

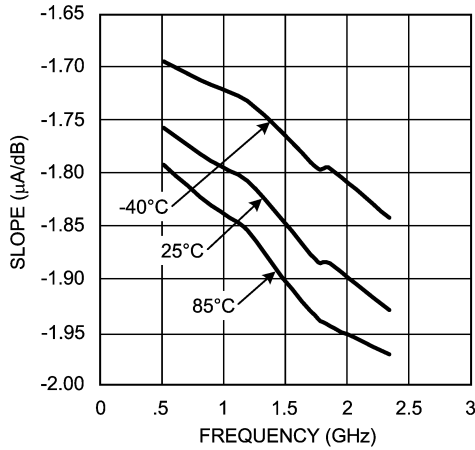

20029006

**Logarithmic Intercept vs. Frequency**

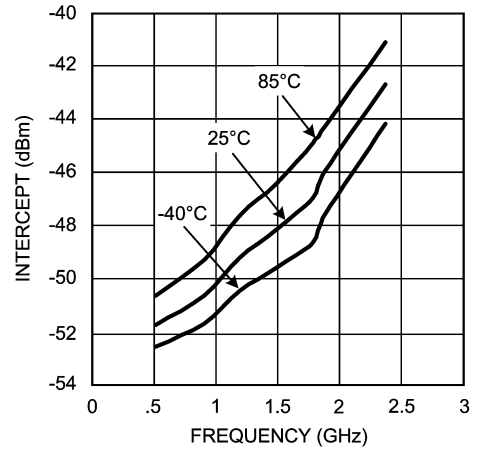

20029007

**RF Input Impedance vs. Frequency @ Resistance and Reactance**

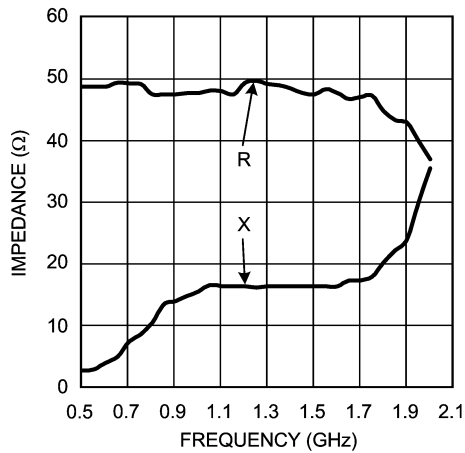

20029031

**Gain and Phase vs. Frequency Error Amplifier**

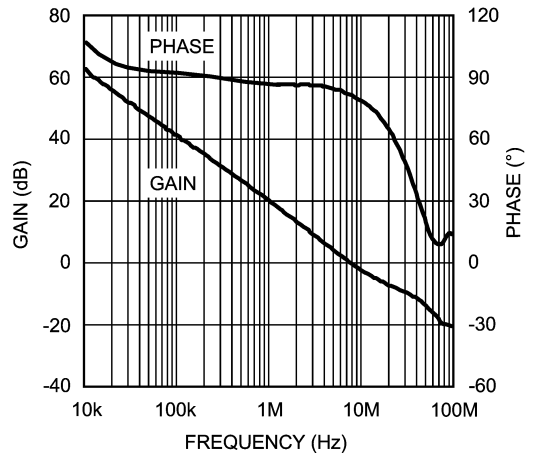

20029026

**Typical Performance Characteristics** Unless otherwise specified,  $V_{DD} = +2.8V$ ,  $T_J = 25^\circ C$ . (Continued)

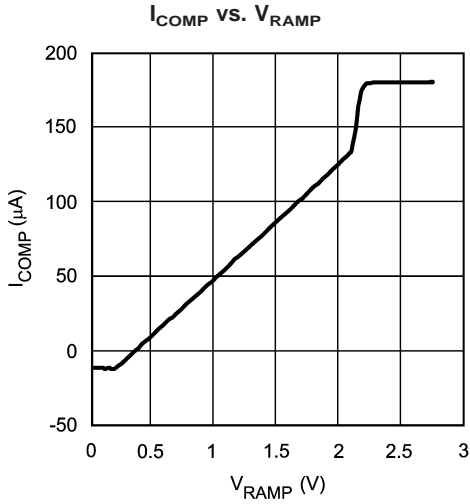

20029027

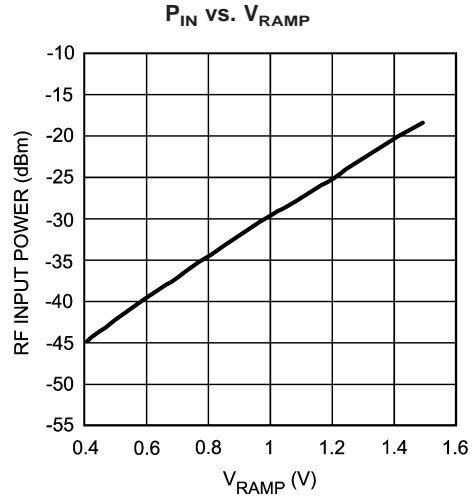

20029028

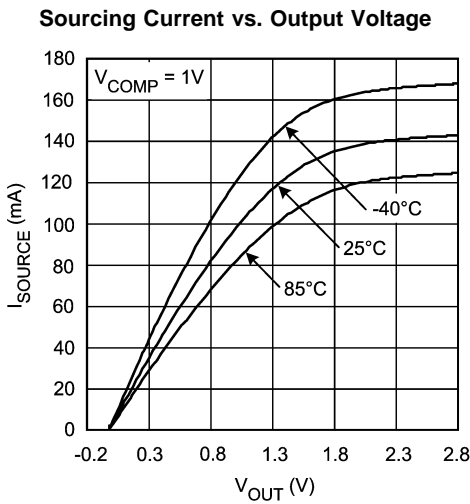

20029032

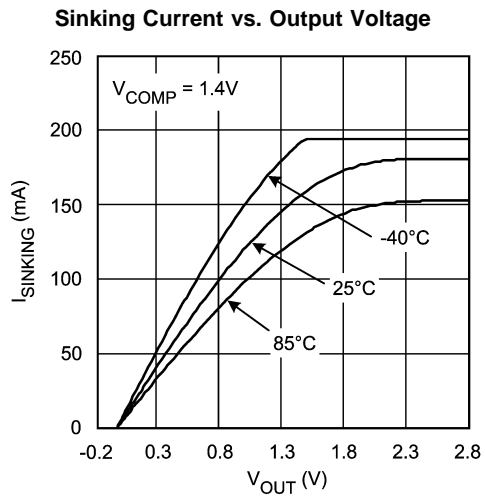

20029033

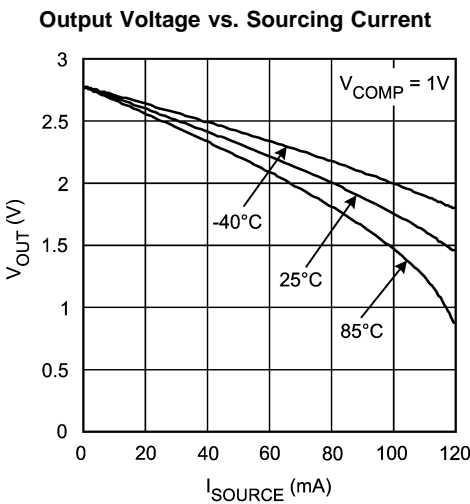

20029029

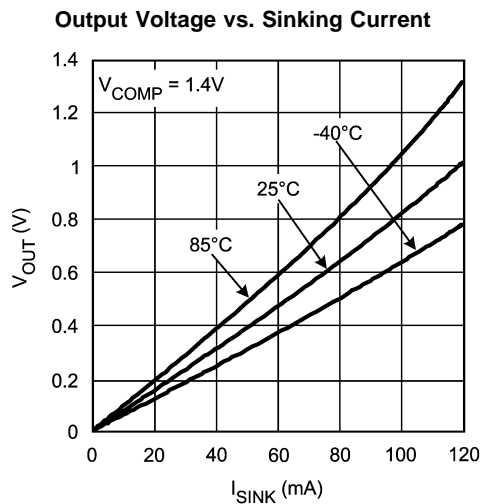

20029030

**Typical Performance Characteristics** Unless otherwise specified,  $V_{DD} = +2.8V$ ,  $T_J = 25^\circ C$ . (Continued)

**Closed Loop  $P_{OUT}$  (PA) vs.  $V_{RAMP}$  @ 900MHz**

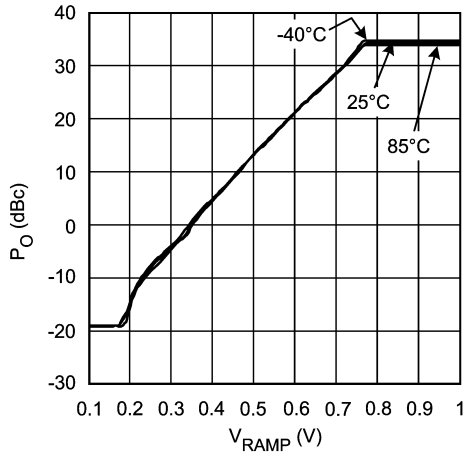

20029011

**Closed Loop  $P_{OUT}$  (PA) vs.  $V_{RAMP}$  @ 1800MHz**

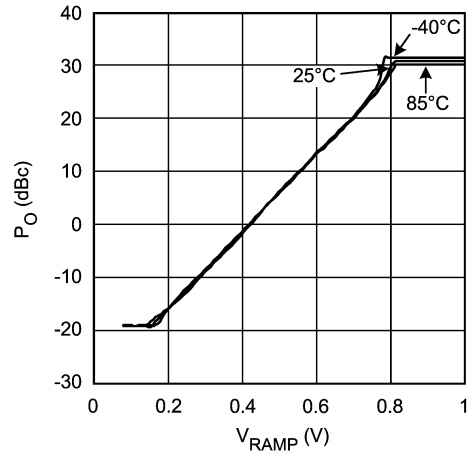

20029012

**Closed Loop  $P_{OUT}$  (PA) vs.  $V_{RAMP}$  @ 1900MHz**

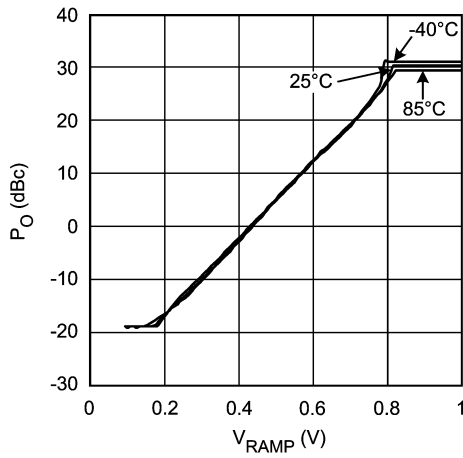

20029013

**Time Mask Plot vs. Time @ 900MHz**

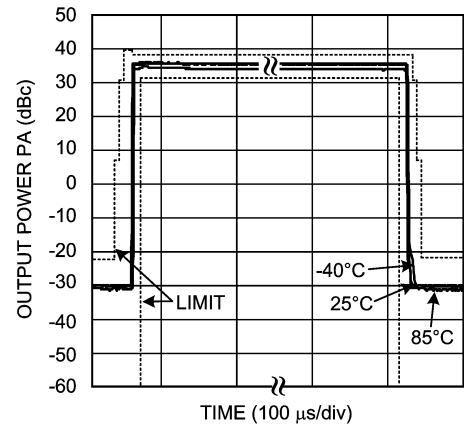

20029014

**Time Mask Plot vs. Time @ 1800MHz**

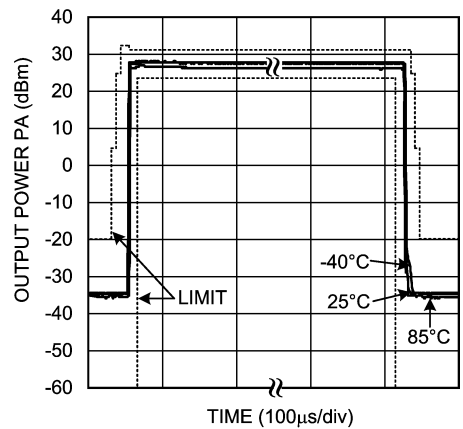

20029015

**Time Mask Plot vs. Time @ 1900MHz**

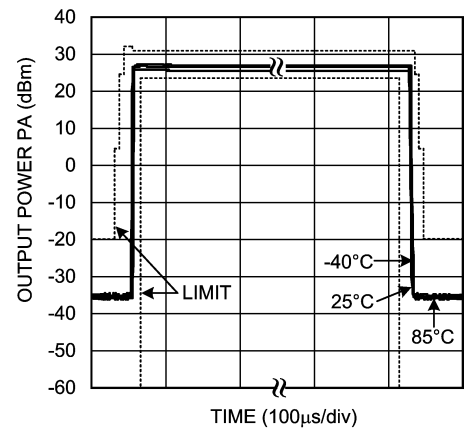

20029016



## Application Information

### 1.0 The LMV243 as an RF Power Amplifier (PA) Controller

The LMV243 is a member of the power loop controller family of National Semiconductor, for a quad-band TDMA/GSM solution. The typical application diagram demonstrates a basic approach for implementing the quad-band solution around the RF Power Amplifier. The LMV243 contains a 50 dB Logamp detector and interfaces directly with the directional coupler.

The LMV243 Base Band (control) interface consists of 2 signals:  $TX\_EN$  to bring the device out of shutdown status within  $5\mu s$ , and  $V_{RAMP}$  for the transmit burst characteristic determining the desired Output Power level. The LMV243 gives maximum flexibility to meet GSM frequency and time mask criteria for many different single supply Power Amplifier types like HBT or, MesFET in GaAs, SiGe or Si technology. This is accomplished by the Programmable Ramp characteristic from the Base Band and the  $TX\_EN$  signal along with the external compensation capacitor.

Power consumption requirements are supported by the  $TX\_EN$  function which puts the entire chip into a Power Saving Mode to enable maximum standby and talk time while ensuring the output does not glitch excessively during Power-up and Power-down.

### 2.0 A Typical GSM Power Amplifier Controlled Loop

This section should give a general overview and understanding of how a typical Power Amplifier control loop works and how to get rid of some of the most common problems confronted in the design. *Figure 2* shows the generic components of such a loop. Beginning at the output of the GSM Power Amplifier (PA), this signal is fed, usually via a directional coupler, to a detector. The output current of the detector  $I_{DET}$  drives the inverting input of an op amp, configured as an integrator. A reference voltage drives the non-inverting input of the op amp. Finally the output of the op amp integrator drives the gain control input of the power amplifier. Now to examine how this circuit works, we will assume initially that the output of the PA is at some low level and that the  $V_{RAMP}$  voltage is at 1V. The V/I converter converts the  $V_{RAMP}$  voltage to a sinking current  $I_{RAMP}$ . This current can only come from the integrator capacitor C. Current flow in this direction increases the output voltage of the integrator. This voltage, which drives the PA, increases the gain (we assume that the PA's gain control input has a positive sense, that is, increasing voltage increases gain). The gain will increase, thereby increasing the amplifier's output level until the detector output current equals the ramp current  $I_{RAMP}$ . At that point, the current through the capacitor will decrease to zero and the integrator output will be held steady, thereby settling the loop. If capacitor charge is lost over time, the gain will decrease. However, this leakage will quickly be corrected by additional integrator current from the newly reduced detector current.

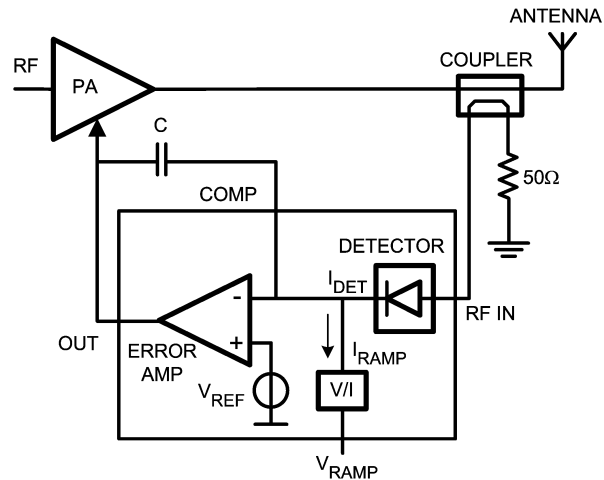

20029037

FIGURE 2. PA Control Loop

The key usefulness of this circuit lies in its immunity to changes in the PA gain control function. From a static perspective at least, the relationship between gain and gain control voltage is of no consequence to the overall transfer function. Based upon the value of  $V_{RAMP}$ , the integrator will set the gain control voltage to whatever level is necessary to produce the desired output level. Any temperature dependency in the gain control function will be eliminated. Also, non-linearity's in the gain transfer function of the PA do not appear in the overall transfer function ( $V_{OUT}$  vs.  $V_{RAMP}$ ). The only requirement is that the gain control function of the PA be monotonic. It is crucial, however, that the detector is temperature stable.

The circuit as described so far, has been designed to produce a constant output level for varying input levels. The only requirement is for it to be temperature stable for input levels that correspond to the setpoint voltage  $V_{RAMP}$ . If the detector used has a higher dynamic range, the circuit to precisely set PA output levels over a wide dynamic range. To do this, the integrator reference voltage,  $V_{RAMP}$ , is varied. The voltage range on  $V_{RAMP}$  follows directly from the detector's transfer function. For example, if the detector delivers 0.5V for an input of  $-7\text{dBm}$ , a reference voltage of 0.5V will cause the loop to settle when the detector input is  $-7\text{dBm}$  (the PA output will be greater than this amount by whatever coupling factor exists between PA and detector). The dynamic range for the variable RF  $P_{OUT}$  case will be determined by the device in the circuit with the least dynamic range (i.e. the gain control range PA or linear dynamic of detector).

## Application Information (Continued)

The response time of this loop can be controlled by varying the RC time constant of the integrator. Setting this at a low level will result in fast output settling but can result in ringing in the output envelope. Settling the RC time constant high will give the loop good stability but will increase settling time.

Figure 3 shows a typical RF power control loop realized by using the National's LMV243 with integrated RF detector. The RF signal from the PA passes through a directional coupler on its way to the antenna. Directional couplers are characterized by their coupling factor which is in the 10dB to 30dB range, typical 20dB. Because the coupled output must in its own right deliver some power (in this case to the detector), the coupling process takes some power from the main output. This manifests itself as insertion loss, the insertion loss being higher for lower coupling factors.

### 3.0 Attenuation between coupler and LMV243 detector

It is very important to choose the right attenuation between PA output and detector input, i.e. the total of coupling factor and extra attenuation, in order to achieve power control over the full output power range of the PA. A typical value for the output power of the PA is +35.5 dBm for GSM and +30 dBm for PCS/DCS. In order to accommodate these levels into the LMV243 detection range the minimum required total attenuation is about 35 dBm (please refer to typical performance characteristics in the datasheet). A typical coupler factor is 20dB. An extra attenuation of about 15 dB should be inserted.

Extra attenuation Z between the coupler and the RF input of the LMV243 can be achieved by 2 resistors  $R_X$  and  $R_Y$  according to Figure 3, where

$$Z = 20 \log [R_{IN} / (R_{IN} + R_Y)]$$

e.g.  $R_Y = 300\Omega$  results in an attenuation of 16.9dB.

To prevent reflection back to the coupler the impedance seen by the coupler should be  $50\Omega$ . The impedance  $R_O$  consists of  $R_X // (R_Y, R_O, + R_{IN})$ .  $R_X$  can be calculated with the formula:

$$R_X = [R_O * (R_Y + R_{IN})] / R_Y$$

$$R_X = 50 * [1 + (50/R_Y)]$$

e.g. with  $R_Y = 300\Omega$ ,  $R_{IN} = 50\Omega \rightarrow R_X = 58\Omega$ .

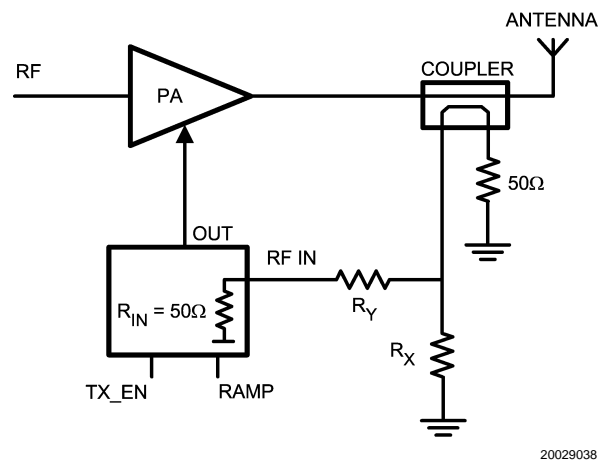

FIGURE 3. PA Control Loop With Extra Attenuation

### 4.0 Components of a Power Amplifier Loop

Figure 3 shows the basics of a typical LMV243 quad-band application.

The key components are:

- The LMV243
- One power amplifier, usually for the GSM and PCN/DCS bands
- A single two channel RF coupler is used instead of the two RF couplers
- A dual or quad-band antenna.

Figure 1 shows the LMV243's internal architecture. The LMV243 contains an RF detector, error amplifier, a ramp V/I converter and an output driver. The LMV243 input interface consists of an RF input, Ramp voltage, and a digital input to perform the function 'Shutdown/Transmit Enable'.

### 5.0 Analog and Digital Input Signals of the LMV243

The LMV243 has the following inputs:

- $V_{RAMP}$  is an analog signal (Base band DAC ramp signal)
- TX\_EN is a digital signal (performs the function 'Shutdown/Transmit Enable').

#### 5.1 $V_{RAMP}$ in signal

The actual  $V_{RAMP}$  input value sets the RF output power. By applying a certain mask shape to the 'Ramp in' pin, the output voltage level of the LMV243 adjusts the PA control voltage to get a power level ( $P_{OUT}/dBm$ ) out of the PA which is proportional to the single ramp voltage steps. The recommended  $V_{RAMP}$  voltage range for RF power control is 0.2V to 2.0V. The  $V_{RAMP}$  input will tolerate voltages from 0V to  $V_{DD}$  without malfunction or damage. The  $V_{RAMP}$  input does not change the output level until the level reaches about 200mV, so offset voltages in the DAC or amplifier supplying the Ramp signal will not cause excess RF signal output and increased power consumption.

### 6.0 Analog Output

The Output is driven by a rail-to-rail amplifier capable of both sourcing and sinking. It is able to source and sink 25mA with less than 200mV voltage drop from either rail over recommended operating conditions. Please refer to the typical performance characteristics. The output voltage vs. Sourcing/Sinking current show the typical voltage drop from the rail over temperature. The Sourcing/Sinking current vs. output voltage characteristics show the typical charging/discharging current, which the output is capable of delivering at a current voltage. The output is free from glitches when enabled by TX\_EN. When TX\_EN is low, the selected output voltage is fixed or near GND.

### 7.0 Bandwidth Compensation

To compensate and prevent the closed loop arrangement from oscillations and overshoots at the output of the RF detector/error amplifier LMV243, the system can be adjusted by means of external RC components connected between Comp and Out. Exact values heavily depend on PA characteristics. A good starting point is  $R = 0\Omega$  and  $C = 68pF$ . The vast combinations of PA's and couplers available preclude a generalized formula for choosing these component. Please contact National Semiconductor for additional assistance.

### 8.0 Evaluation Board

An evaluation board is available for the LMV243. Please contact your local distributor or National Semiconductor sales office.

# Typical Timing Diagram

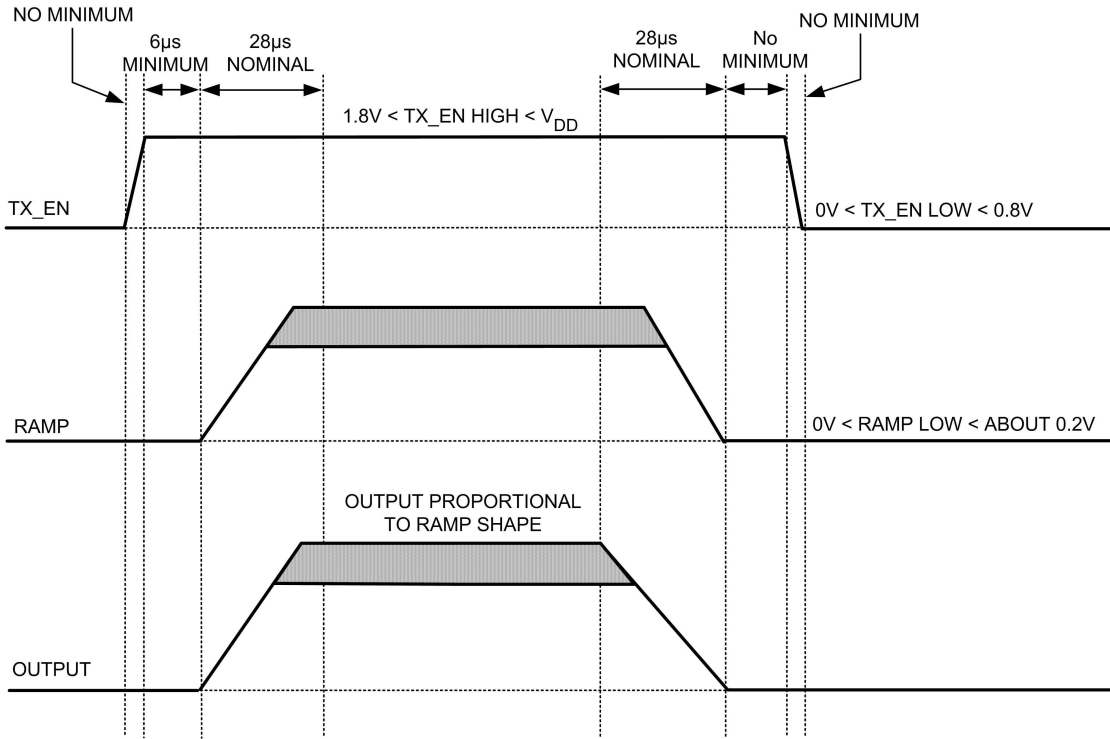

20029039

## Typical Test Setup Diagram

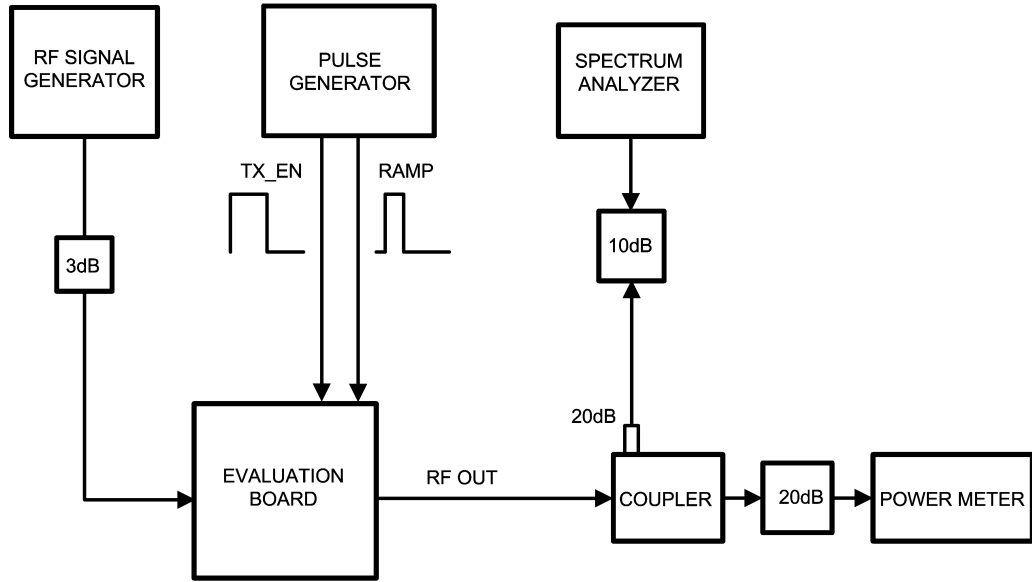

20029022

### Equipment List:

**RF Signal Generator**

Pulse Generator

Spectrum Analyzer

Power Meter

Coupler

**Rohde & Schwarz SMIQ 03B**

Tektronix AFG2020

Rohde & Schwarz FSP

HP E4418B, with Powersensor HP E4413A

Pasternack PE 2208-10

## Physical Dimensions inches (millimeters)

unless otherwise noted

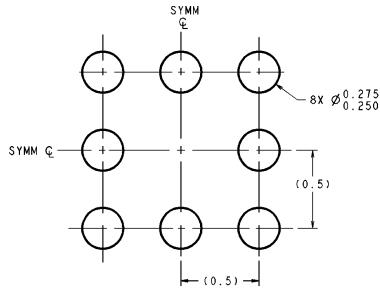

DIMENSIONS ARE IN MILLIMETERS

### LAND PATTERN RECOMMENDATION

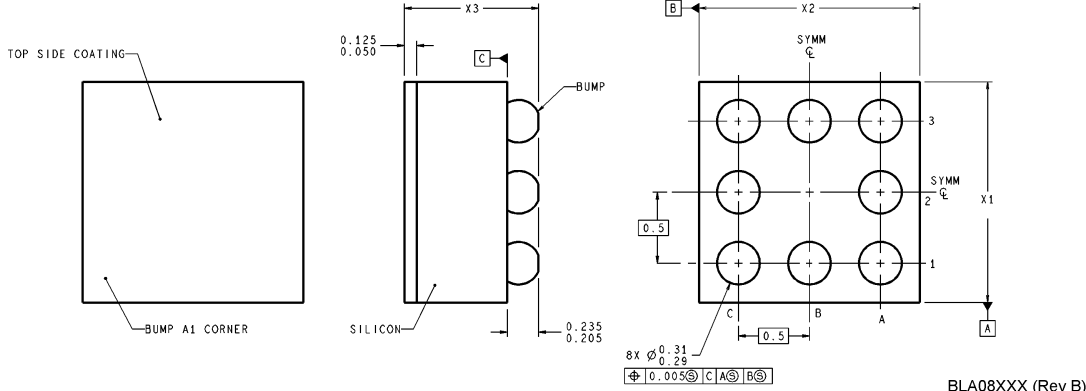

### 8-Bump micro SMD NS Package Number BLA08AAC

$X1 = 1.514 \pm 0.03\text{mm}$   $X2 = 1.514 \pm 0.03\text{mm}$   $X3 = 0.995 \pm 0.1\text{mm}$

NOTES: UNLESS OTHERWISE SPECIFIED

1. EPOXY COATING
2. Sn/37Pb EUTECTIC BUMP
3. RECOMMEND NON-SOLDER MASK DEFINED LANDING PAD.
4. PIN A1 IS ESTABLISHED BY LOWER LEFT CORNER WITH RESPECT TO TEXT ORIENTATION. REMAINING PINS ARE NUMBERED COUNTER CLOCKWISE.
5. XXX IN DRAWING NUMBER REPRESENTS PACKAGE SIZE VARIATION WHERE X1 IS PACKAGE WIDTH, X2 IS PACKAGE LENGTH AND X3 IS PACKAGE HEIGHT.

REFERENCE JEDEC REGISTRATION MO-211, VARIATION BC.

### LIFE SUPPORT POLICY

NATIONAL'S PRODUCTS ARE NOT AUTHORIZED FOR USE AS CRITICAL COMPONENTS IN LIFE SUPPORT DEVICES OR SYSTEMS WITHOUT THE EXPRESS WRITTEN APPROVAL OF THE PRESIDENT AND GENERAL COUNSEL OF NATIONAL SEMICONDUCTOR CORPORATION. As used herein:

1. Life support devices or systems are devices or systems which, (a) are intended for surgical implant into the body, or (b) support or sustain life, and whose failure to perform when properly used in accordance with instructions for use provided in the labeling, can be reasonably expected to result in a significant injury to the user.
2. A critical component is any component of a life support device or system whose failure to perform can be reasonably expected to cause the failure of the life support device or system, or to affect its safety or effectiveness.



**National Semiconductor Corporation**  
Americas  
Email: support@nsc.com

**National Semiconductor Europe**  
Fax: +49 (0) 180-530 85 86  
Email: europe.support@nsc.com  
Deutsch Tel: +49 (0) 69 9508 6208  
English Tel: +44 (0) 870 24 0 2171  
Français Tel: +33 (0) 1 41 91 8790

**National Semiconductor Asia Pacific Customer Response Group**  
Tel: 65-2544466  
Fax: 65-2504466  
Email: ap.support@nsc.com

**National Semiconductor Japan Ltd.**  
Tel: 81-3-5639-7560  
Fax: 81-3-5639-7507

www.national.com

This datasheet has been download from:

[www.datasheetcatalog.com](http://www.datasheetcatalog.com)

Datasheets for electronics components.

# National Semiconductor was acquired by Texas Instruments.

[http://www.ti.com/corp/docs/investor\\_relations/pr\\_09\\_23\\_2011\\_national\\_semiconductor.html](http://www.ti.com/corp/docs/investor_relations/pr_09_23_2011_national_semiconductor.html)

This file is the datasheet for the following electronic components:

LMV243 - <http://www.ti.com/product/lmv243?HQS=TI-null-null-dscatalog-df-pf-null-ww>