

Électronique

TD Filtrage

May 6, 2020

Synthèse d'un filtre passe-bande

Le but est ici de concevoir un filtre passe-bande, en utilisant deux structures différentes, et en respectant le cahier des charges suivant:

Type de filtre	Passe-bande
Fréquence centrale	10 kHz
Bande passante (BP)	$B = 1$ kHz
Bande d'atténuation (BA)	$B' = 3$ kHz
Atténuation minimale dans la BA	10 dB
Contrainte	Amplitude la plus plate possible dans la BP

1 Fonction de transfert du filtre

1. En utilisant le cahier de charges, dessiner le gabarit correspondant.
2. Normaliser le filtre en calculant les fréquences à X dB.
3. En utilisant les abaqes pour les filtres passe-bas normalisés fournies à la fin du document, déterminer le type et l'ordre du filtre qui répond au cahier des charges.
4. Donner la fonction de transfert du filtre passe-bas normalisé correspondant. On donne la forme générale des racines des polynômes de Butterworth en fonction de l'ordre n ($k \leq n$):

$$s_k = -\sin\left(\frac{2k-1}{2n}\pi\right) \pm i \cos\left(\frac{2k-1}{2n}\pi\right)$$

5. En utilisant le changement de variable suivant, calculer la fonction de transfert du filtre après dé-normalisation:

$$f \rightarrow \frac{f_c}{B} \left(\frac{f}{f_c} - \frac{f_c}{f} \right)$$

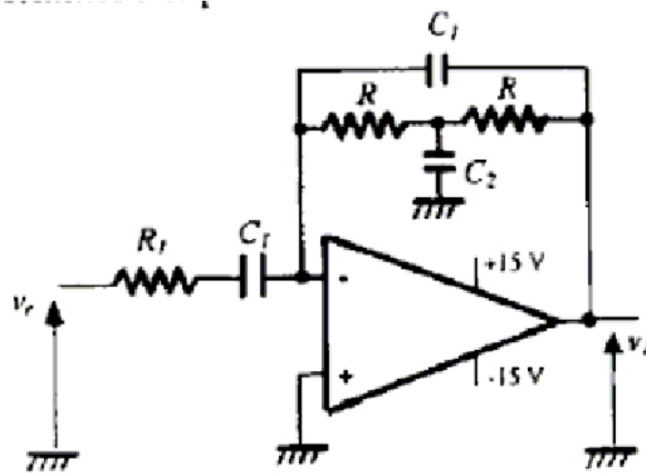

Figure 1: Première implémentation du filtre.

2 Première implémentation

On implémente tout d'abord le filtre en utilisant la structure présentée sur la figure 1, avec $R_1 = (RC_2)/(2C_1)$. On donne la fonction de transfert sur filtre:

$$H(j\omega) = \frac{v_{\text{out}}}{v_{\text{in}}} = \frac{-\frac{j\omega}{Q\omega_0}}{1 + \frac{j\omega}{Q\omega_0} + \left(\frac{\omega}{\omega_0}\right)^2}$$

où $Q = \frac{1}{2}\sqrt{\frac{C_2}{C_1}}$ and $\omega_0 = \frac{1}{R\sqrt{C_1C_2}}$.

6. En identifiant cette fonction de transfert à la fonction de transfert obtenu dans la partie 1, déterminer la valeur des capacités. On prendra $R = 10 \text{ k}\Omega$.

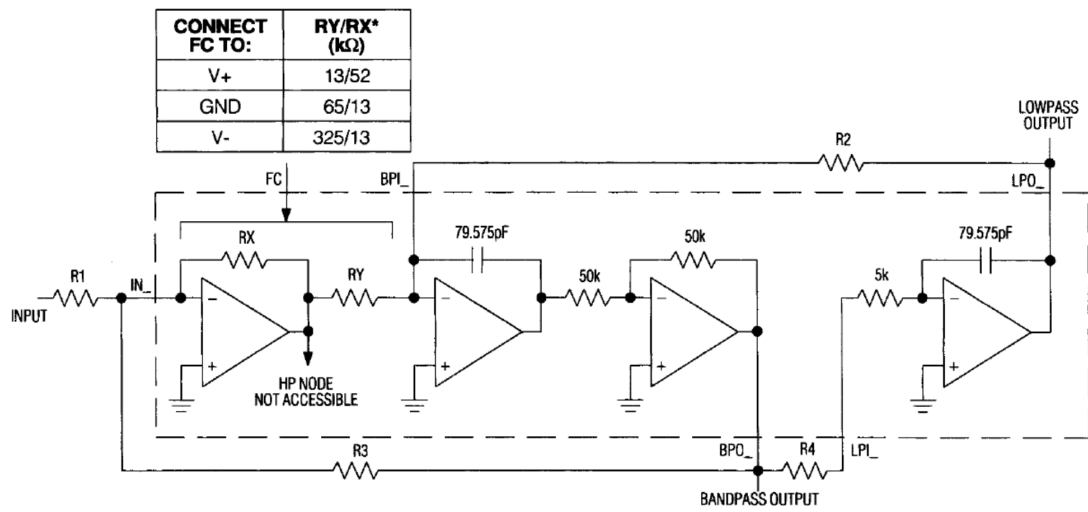

Figure 2: Seconde implémentation du filtre.

3 Implémentation avec la structure Biquad.

On désire maintenant réaliser le filtre en utilisant la structure Biquad présentée sur la figure 2. La fonction de transfert de ce filtre est donnée:

$$H_{BP}(s) = K' \frac{s \frac{\omega_0}{Q}}{s^2 + s \frac{\omega_0}{Q} + \omega_0^2}$$

avec $\omega_0 = \frac{1}{C \sqrt{R_2(R_4+5 \text{ k}\Omega)}}$, $Q = \frac{R_3}{\sqrt{R_2(R_4+5 \text{ k}\Omega)}} \left(\frac{R_Y}{R_X} \right)$ et $K' = \frac{R_3}{R_1}$.

- Déterminer les résistances R_1 , R_2 , R_3 , et R_4 nécessaires pour obtenir un filtre pass-bande respectant le cahier des charges de départ.

**ANALOG FILTERS
STANDARD RESPONSES**

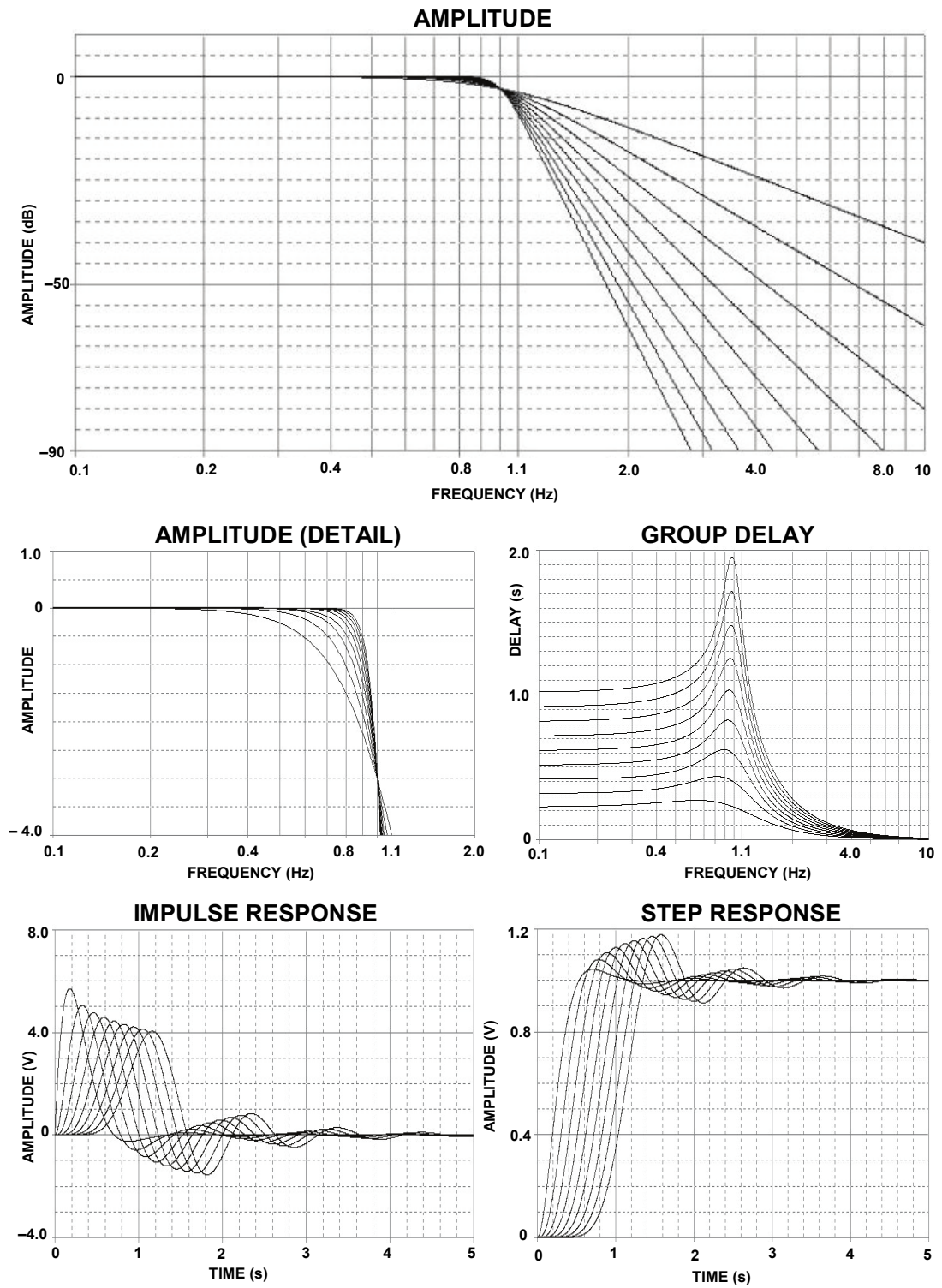

Figure 8.15: Butterworth Response

▣ BASIC LINEAR DESIGN

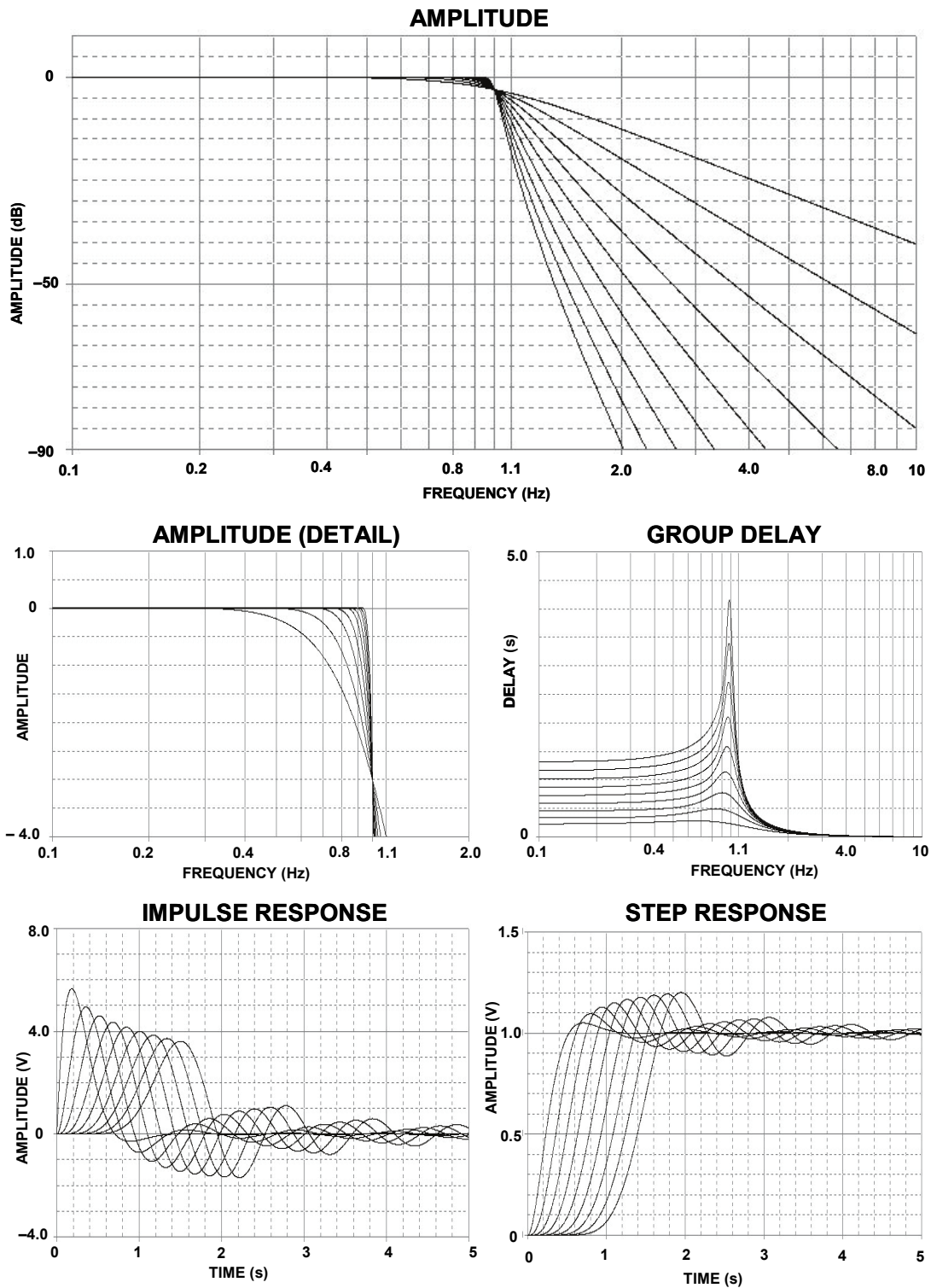

Figure 8.16: 0.01 dB Chebyshev Response

**ANALOG FILTERS
STANDARD RESPONSES**

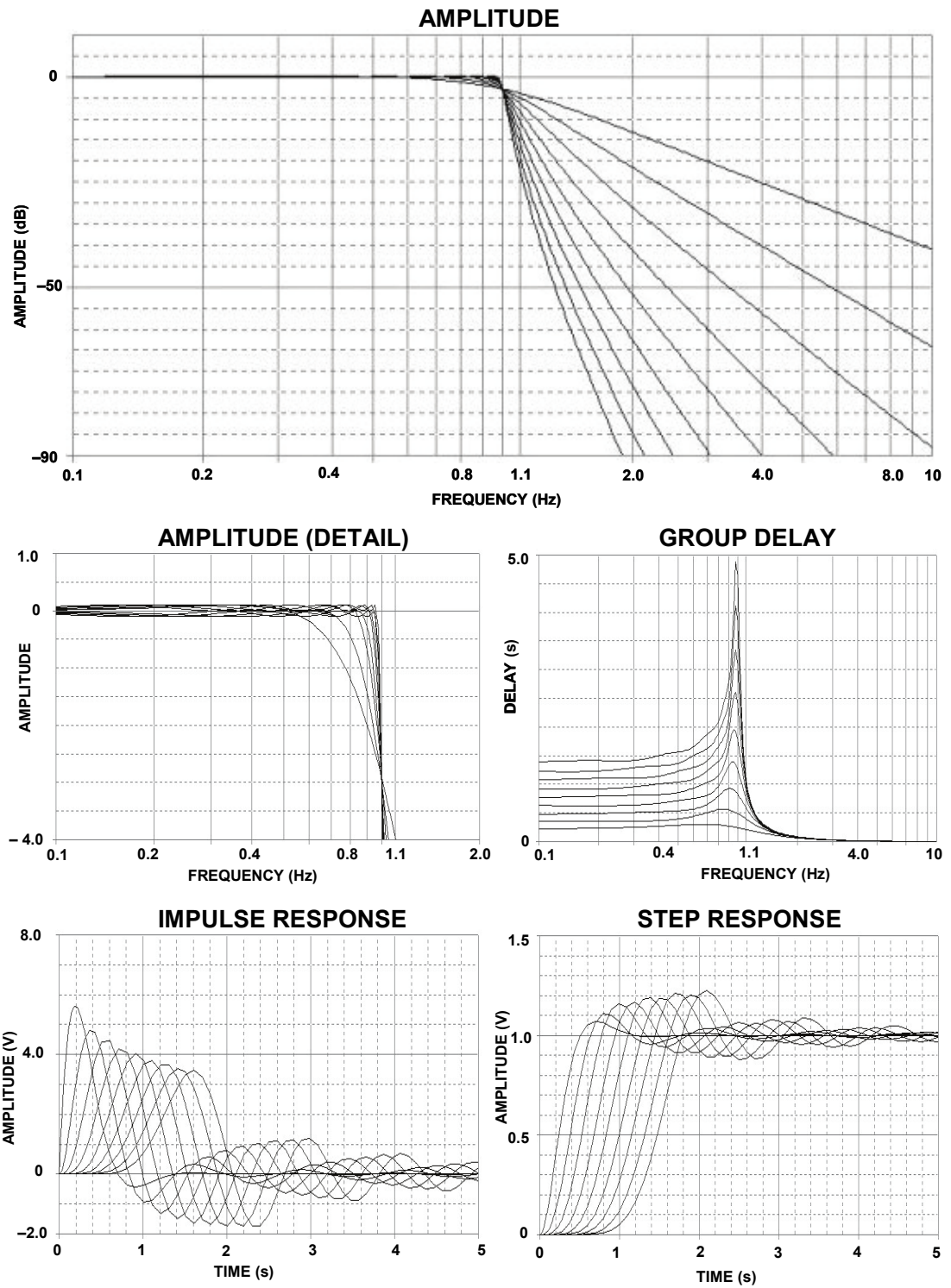

Figure 8.17: 0.1 dB Chebyshev Response

▣ BASIC LINEAR DESIGN

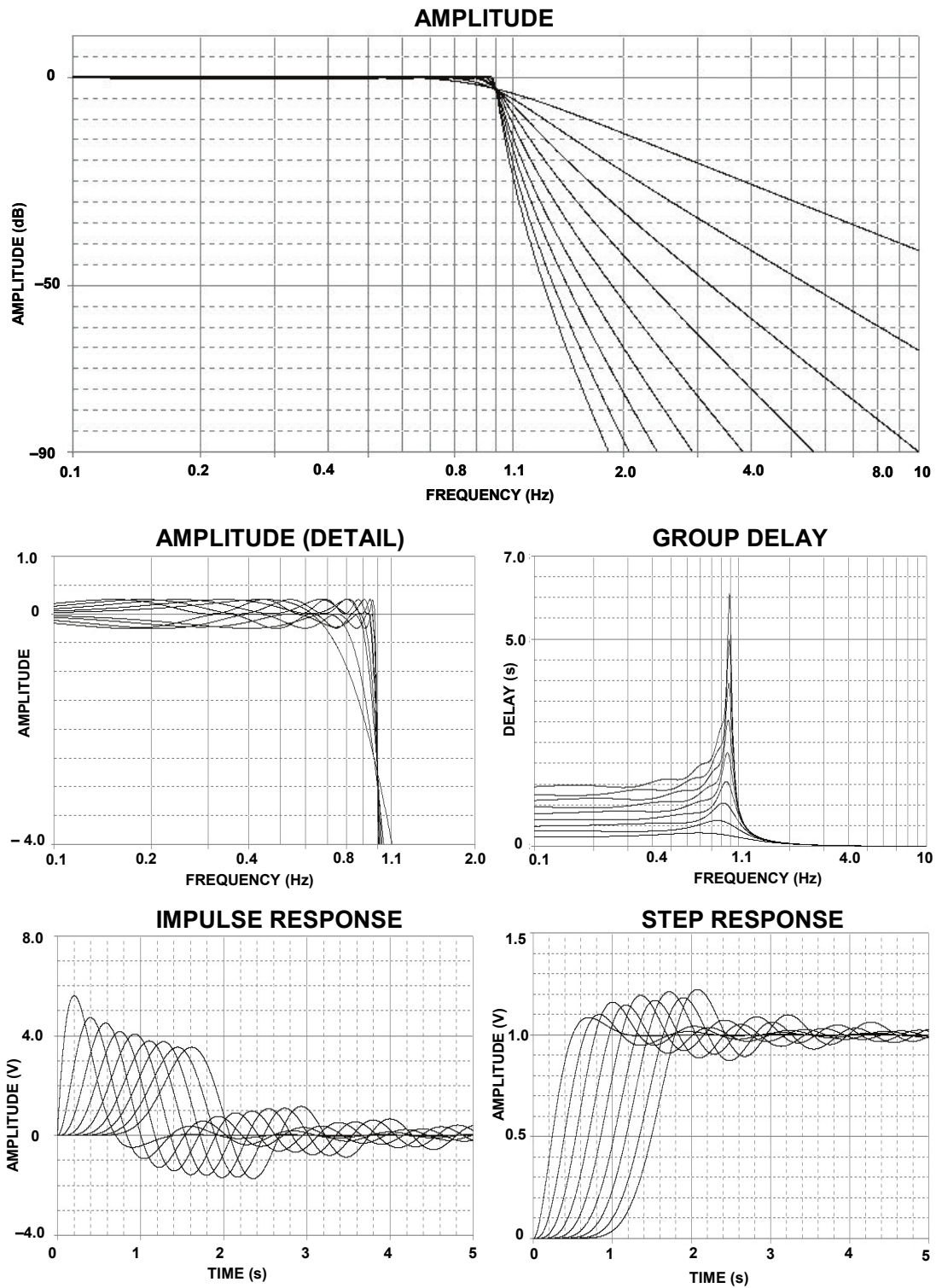

Figure 8.18: 0.25 dB Chebyshev Response

**ANALOG FILTERS
STANDARD RESPONSES**

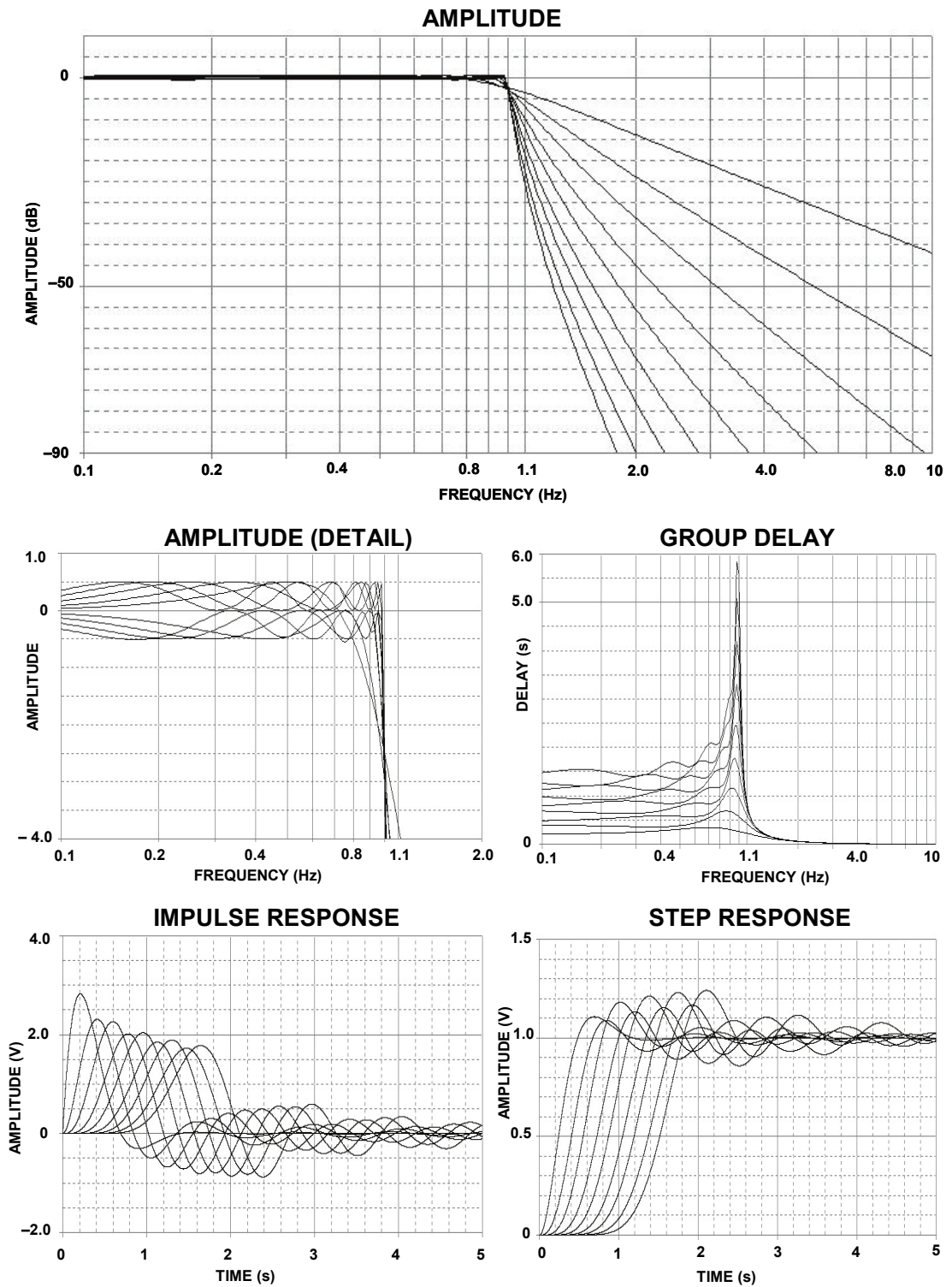

Figure 8.19: 0.5 dB Chebyshev Response

▣ BASIC LINEAR DESIGN

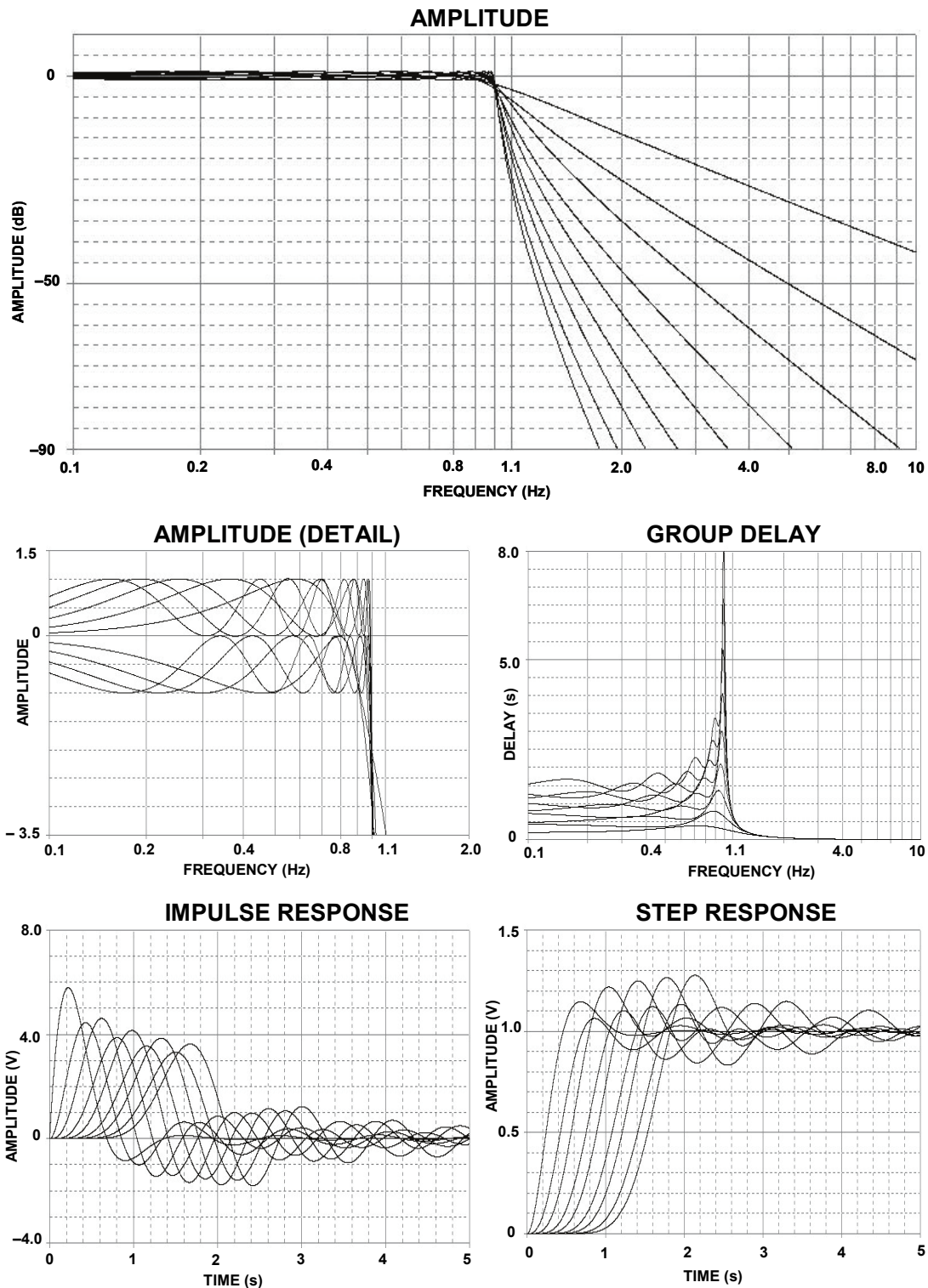

Figure 8.20: 1 dB Chebyshev Response

**ANALOG FILTERS
STANDARD RESPONSES**

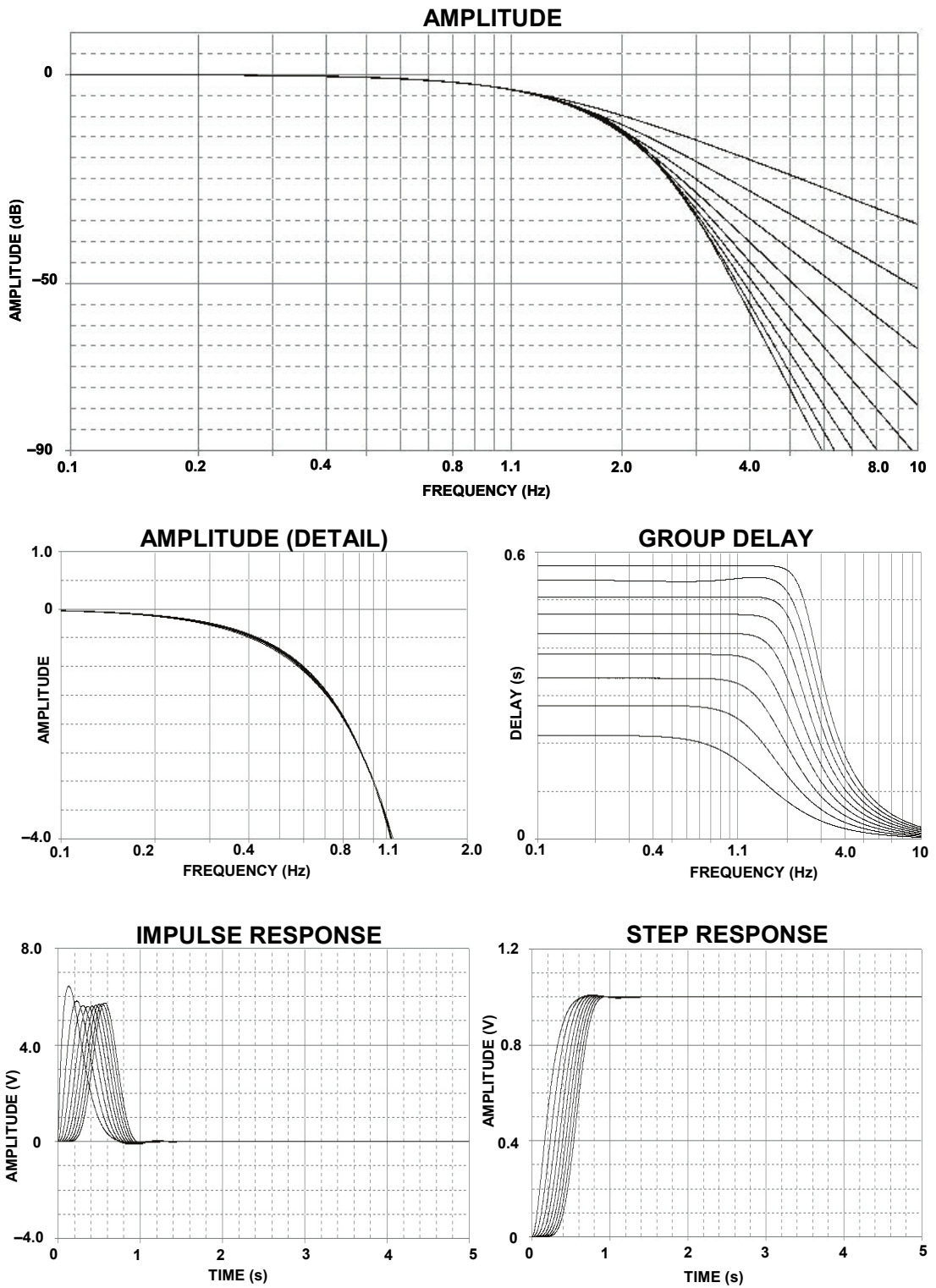

Figure 8.21: Bessel Response

▣ BASIC LINEAR DESIGN

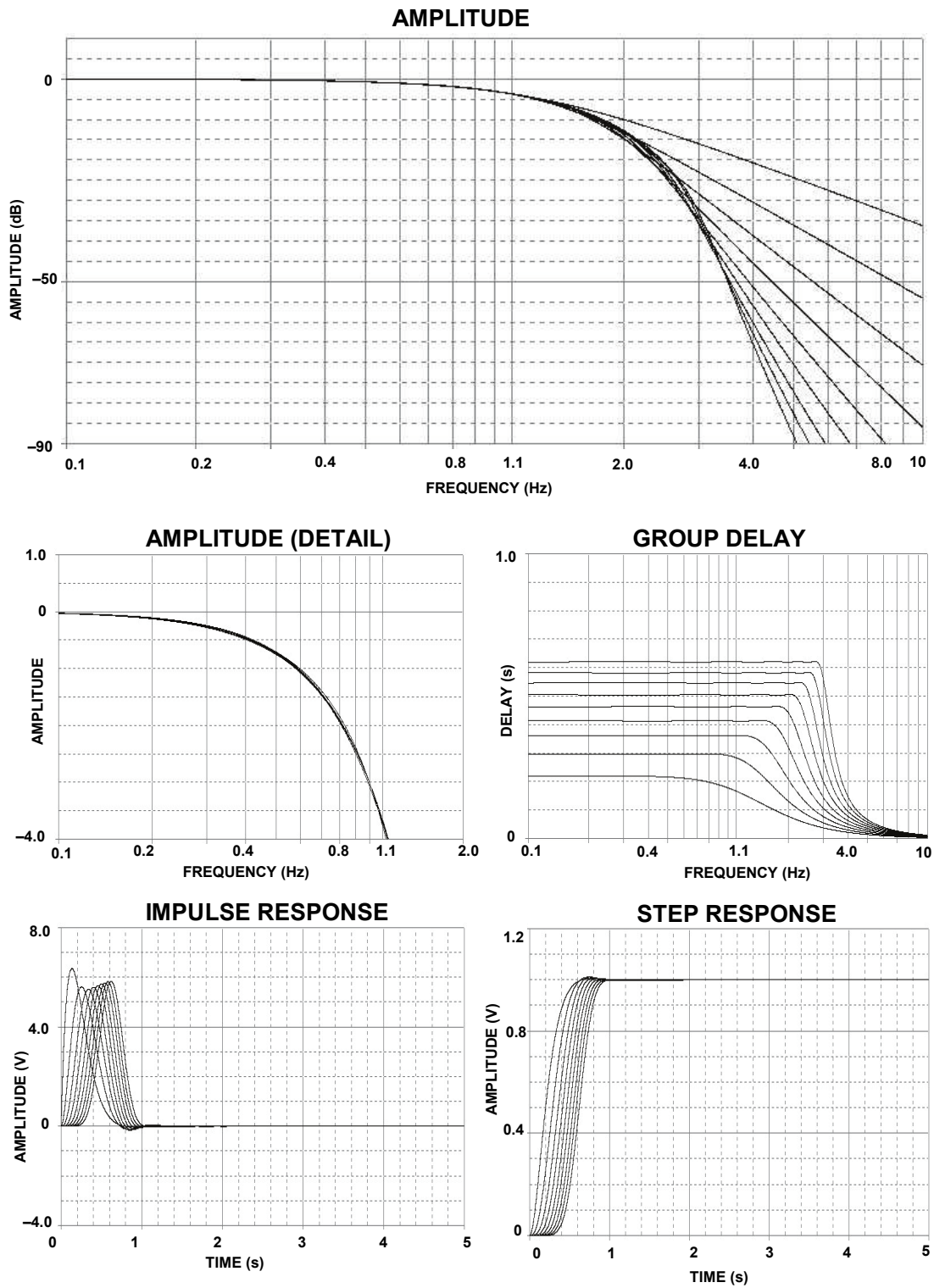

Figure 8.22: Linear Phase Response with Equiripple Error of 0.05°

**ANALOG FILTERS
STANDARD RESPONSES**

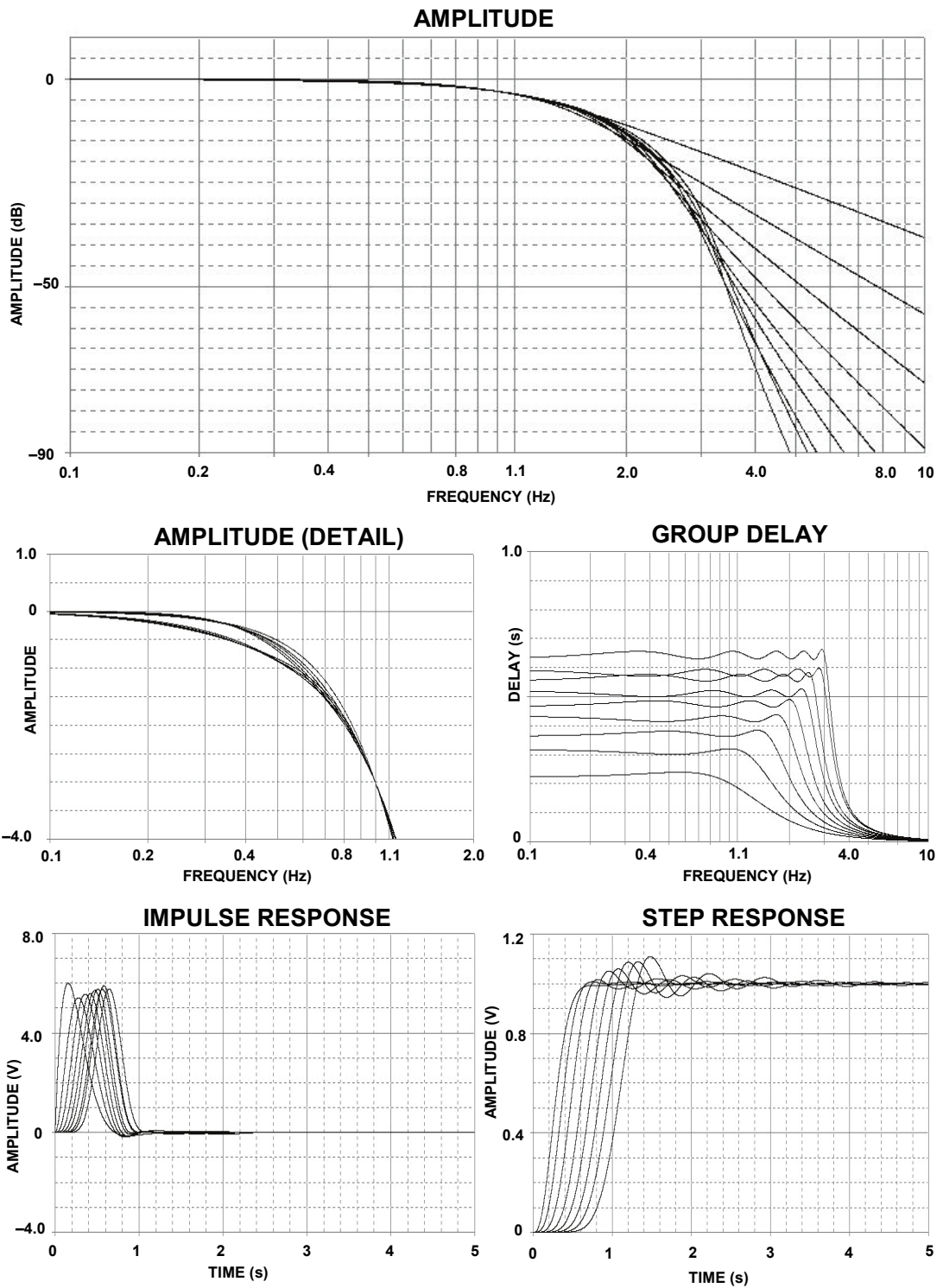

Figure 8.23: Linear Phase Response with Equiripple Error of 0.5°

▣ BASIC LINEAR DESIGN

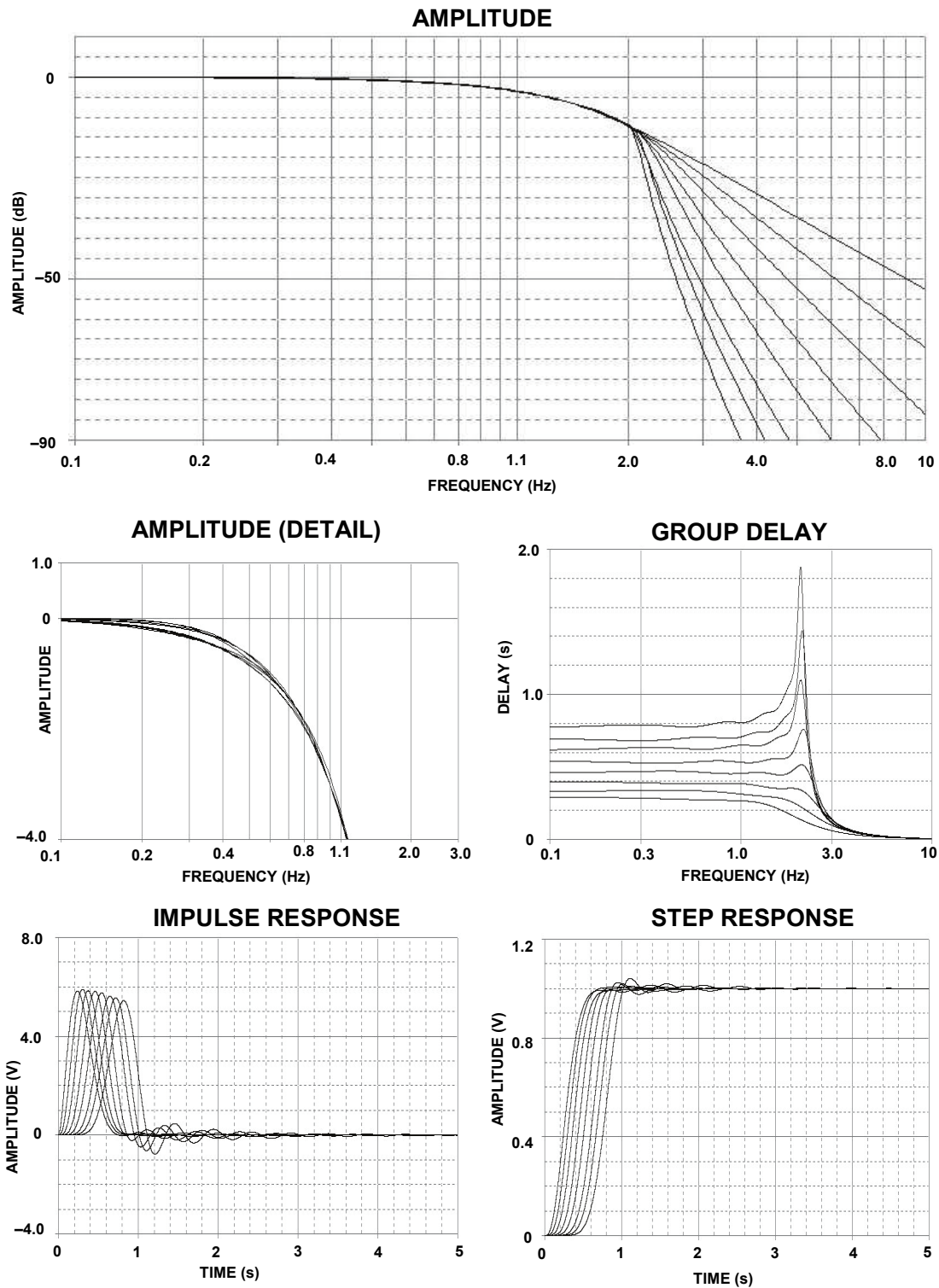

Figure 8.24: Gaussian to 12 dB Response

**ANALOG FILTERS
STANDARD RESPONSES**

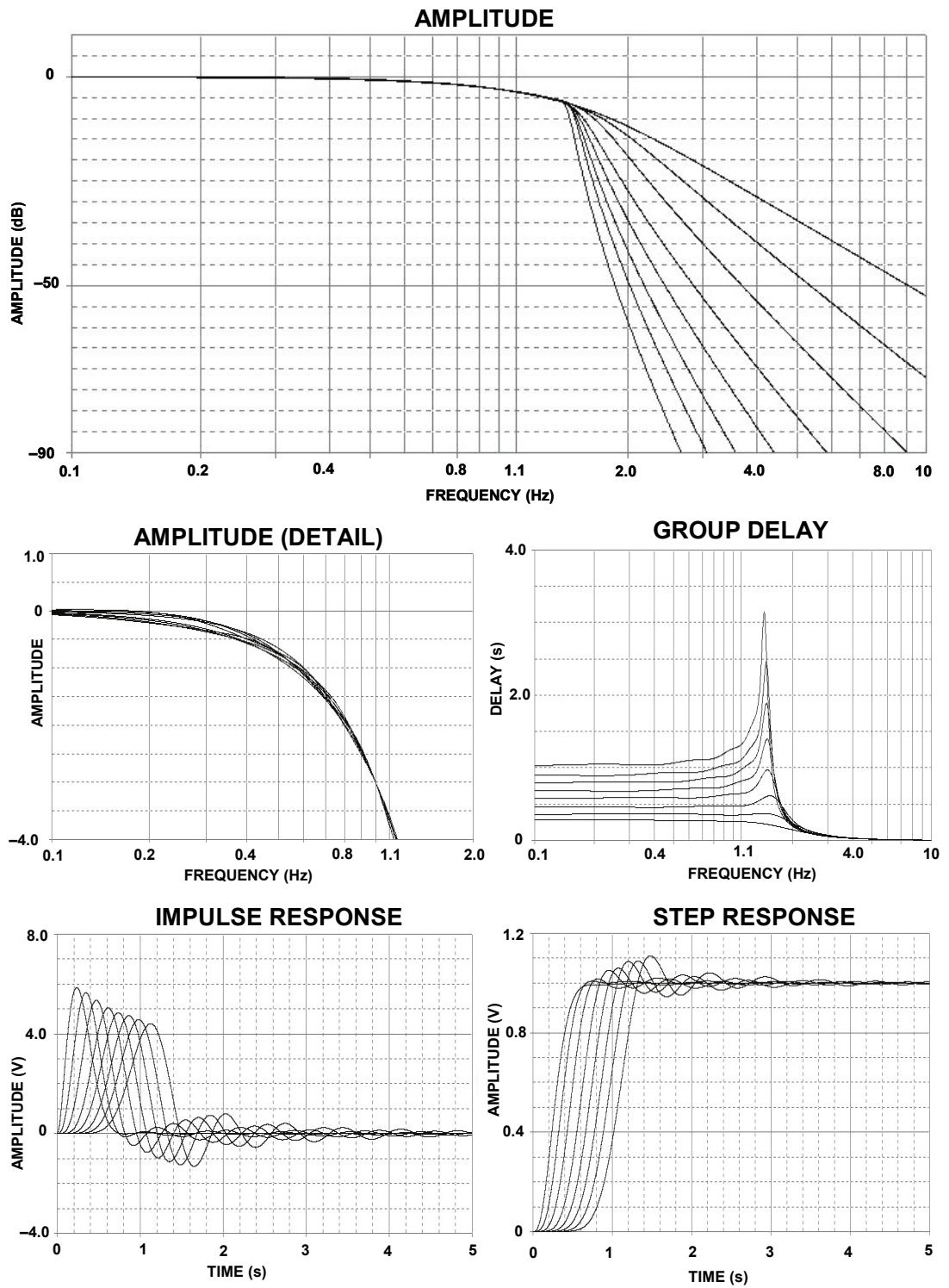

Figure 8.25: Gaussian to 6 dB Response

▣ BASIC LINEAR DESIGN

ORDER	SECTION	REAL		IMAGINARY		F _o	α	Q	-3 dB		PEAKING LEVEL
		PART	PART	PART	PART				FREQUENCY	FREQUENCY	
2	1	0.7071	0.7071	0.7071	0.7071	1.0000	1.4142	0.7071	1.0000		
3	1	0.5000	0.8660	0.8660	0.5000	1.0000	1.0000	1.0000	1.0000	0.7071	1.2493
	2	1.0000				1.0000					
4	1	0.9239	0.3827	0.3827	0.9239	1.0000	1.8478	0.5412	0.7195		
	2	0.3827	0.9239	0.9239	0.3827	1.0000	0.7654	1.3065		0.8409	3.0102
5	1	0.8090	0.5878	0.5878	0.8090	1.0000	1.6180	0.6180	0.8588		
	2	0.3090	0.9511	0.9511	0.3090	1.0000	0.6180	1.6182		0.8995	4.6163
	3	1.0000				1.0000			1.0000		
6	1	0.9659	0.2588	0.2588	0.9659	1.0000	1.9319	0.5176	0.6758		
	2	0.7071	0.7071	0.7071	0.7071	1.0000	1.4142	0.7071	1.0000		
	3	0.2588	0.9659	0.9659	0.2588	1.0000	0.5176	1.9319		0.9306	6.0210
7	1	0.9010	0.4339	0.4339	0.9010	1.0000	1.8019	0.5550	0.7449		
	2	0.6235	0.7818	0.7818	0.6235	1.0000	1.2470	0.8019		0.4717	0.2204
	3	0.2225	0.9749	0.9749	0.2225	1.0000	0.4450	2.2471		0.9492	7.2530
	4	1.0000				1.0000			1.0000		
8	1	0.9808	0.1951	0.1951	0.9808	1.0000	1.9616	0.5098	0.6615		
	2	0.8315	0.5556	0.5556	0.8315	1.0000	1.6629	0.6013	0.8295		
	3	0.5556	0.8315	0.8315	0.5556	1.0000	1.1112	0.9000		0.6186	0.6676
	4	0.1951	0.9808	0.9808	0.1951	1.0000	0.3902	2.5628		0.9612	8.3429
9	1	0.9397	0.3420	0.3420	0.9397	1.0000	1.8794	0.5321	0.7026		
	2	0.7660	0.6428	0.6428	0.7660	1.0000	1.5320	0.6527	0.9172		
	3	0.5000	0.8660	0.8660	0.5000	1.0000	1.0000	1.0000		0.7071	1.2493
	4	0.1737	0.9848	0.9848	0.1737	1.0000	0.3474	2.8785		0.9694	9.3165
	5	1.0000				1.0000			1.0000		
10	1	0.9877	0.1564	0.1564	0.9877	1.0000	1.9754	0.5062	0.6549		
	2	0.8910	0.4540	0.4540	0.8910	1.0000	1.7820	0.5612	0.7564		
	3	0.7071	0.7071	0.7071	0.7071	1.0000	1.4142	0.7071	1.0000		
	4	0.4540	0.8910	0.8910	0.4540	1.0000	0.9080	1.1013		0.7667	1.8407
	5	0.1564	0.9877	0.9877	0.1564	1.0000	0.3128	3.1970		0.9752	10.2023

Figure 8.26: Butterworth Design Table

**ANALOG FILTERS
STANDARD RESPONSES**

ORDER SECTION	REAL PART	IMAGINARY PART	F ₀	α	Q	-3 dB FREQUENCY	PEAKING FREQUENCY	PEAKING LEVEL
2	1	0.6743	0.7075	0.9774	1.3798	0.7247	0.2142	0.0100
3	1	0.4233	0.8663	0.9642	0.8780	1.1389	0.7558	2.0595
	2	0.8467		0.8467		0.8467		
4	1	0.6762	0.3628	0.7770	1.7405	0.5746	0.8806	5.1110
	2	0.2801	0.9241	0.9656	0.5801	1.7237		
5	1	0.5120	0.5879	0.7796	1.3135	0.7613	0.2889	0.0827
	2	0.1956	0.9512	0.9711	0.4028	2.4824	0.9309	8.0772
	3	0.6328		0.6328		0.6328		
6	1	0.5335	0.2588	0.5930	1.7995	0.5557	0.4425	
	2	0.3906	0.7072	0.8079	0.9670	1.0342	0.5895	1.4482
	3	0.1430	0.9660	0.9765	0.2929	3.4144	0.9554	10.7605
7	1	0.4393	0.4339	0.6175	1.4229	0.7028	0.6136	
	2	0.3040	0.7819	0.8389	0.7247	1.3798	0.7204	3.4077
	3	0.1085	0.9750	0.9810	0.2212	4.5208	0.9689	13.1578
	4	0.4876		0.4876		0.4876		
8	1	0.4268	0.1951	0.4693	1.8190	0.5498	0.3451	
	2	0.3168	0.5556	0.6396	0.9907	1.0094	0.4564	1.3041
	3	0.2418	0.8315	0.8659	0.5585	1.7906	0.7956	5.4126
	4	0.0849	0.9808	0.9845	0.1725	5.7978	0.9771	15.2977
9	1	0.3686	0.3420	0.5028	1.4661	0.6821	0.4844	
	2	0.3005	0.6428	0.7096	0.8470	1.1807	0.5682	2.3008
	3	0.1961	0.8661	0.8880	0.4417	2.2642	0.8436	7.3155
	4	0.0681	0.9948	0.9872	0.1380	7.2478	0.9824	17.2249
	5	0.3923		0.3923		0.3923		
10	1	0.3522	0.1564	0.3654	1.8279	0.5471	0.2814	
	2	0.3178	0.454	0.5542	1.1469	0.8719	0.3242	0.5412
	3	0.2522	0.7071	0.7507	0.6719	1.4884	0.6606	3.9742
	4	0.1619	0.891	0.9056	0.3576	2.7968	0.8762	9.0742
	5	0.0558	0.9877	0.9893	0.1128	8.8645	0.9861	18.9669

Figure 8.27: 0.01 dB Chebyshev Design Table

▣ BASIC LINEAR DESIGN

ORDER	SECTION	REAL PART	IMAGINARY PART	F_0	α	Q	-3 dB FREQUENCY	PEAKING FREQUENCY	PEAKING LEVEL
2	1	0.6104	0.7106	0.9368	1.3032	0.7673		0.3638	0.0999
3	1	0.3490	0.8684	0.9359	0.7458	1.3408		0.7952	3.1978
	2	0.6970		0.6970			0.6970		
4	1	0.2177	0.9254	0.9507	0.4580	2.1834		0.8994	7.0167
	2	0.5257	0.3833	0.6506	1.6160	0.6188	0.5596		
5	1	0.3842	0.5884	0.7027	1.0935	0.9145		0.4457	0.7662
	2	0.1468	0.9521	0.9634	0.3048	3.2812		0.9407	10.4226
	3	0.4749		0.4749			0.4749		
6	1	0.3916	0.2590	0.4695	1.6682	0.5995	0.3879		
	2	0.2867	0.7077	0.7636	0.7509	1.3316		0.6470	3.1478
	3	0.1049	0.9667	0.9724	0.2158	4.6348		0.9610	13.3714
7	1	0.3178	0.4341	0.5380	1.1814	0.8464		0.2957	0.4157
	2	0.2200	0.7823	0.8126	0.5414	1.8469		0.7507	5.6595
	3	0.0785	0.9755	0.9787	0.1604	6.2335		0.9723	15.9226
	4	0.3528		0.3528			0.3528		
8	1	0.3058	0.1952	0.3628	1.6858	0.5932	0.2956		
	2	0.2529	0.5558	0.6106	0.8283	1.2073		0.4949	2.4532
	3	0.1732	0.8319	0.8497	0.4077	2.4531		0.8137	7.9784
	4	0.0608	0.9812	0.9831	0.1237	8.0819		0.9793	18.1669
9	1	0.2622	0.3421	0.4310	1.2166	0.8219		0.2197	0.3037
	2	0.2137	0.6430	0.6776	0.6308	1.5854		0.6064	4.4576
	3	0.1395	0.8663	0.8775	0.3180	3.1450		0.8550	10.0636
	4	0.0485	0.9852	0.9864	0.0982	10.1795		0.9840	20.1650
	5	0.2790		0.2790			0.2790		
10	1	0.2493	0.1564	0.2943	1.6942	0.5902	0.2382		
	2	0.2249	0.4541	0.5067	0.8876	1.1266		0.3945	1.9880
	3	0.1785	0.7073	0.7295	0.4894	2.0434		0.6844	6.4750
	4	0.1146	0.8913	0.8986	0.2551	3.9208		0.8839	11.9386
	5	0.0395	0.9880	0.9888	0.0799	12.5163		0.9872	21.9565

Figure 8.28: 0.1 dB Chebyshev Design Table

**ANALOG FILTERS
STANDARD RESPONSES**

ORDER	SECTION	REAL PART	IMAGINARY PART	F ₀	α	Q	-3 dB FREQUENCY	PEAKING FREQUENCY	PEAKING LEVEL
2	1	0.5621	0.7154	0.9098	1.2356	0.8093		0.4425	0.2502
3	1	0.3062	0.8712	0.9234	0.6632	1.5079		0.8156	4.0734
	2	0.6124		0.6124			0.6124		
4	1	0.4501	0.3840	0.5916	1.5215	0.6572	0.5470		
	2	0.1865	0.9272	0.9458	0.3944	2.5356		0.9082	8.2538
5	1	0.3247	0.5892	0.6727	0.9653	1.0359		0.4917	1.4585
	2	0.1240	0.9533	0.9613	0.2580	3.8763		0.9452	11.8413
	3	0.4013		0.4013			0.4013		
6	1	0.3284	0.2593	0.4184	1.5697	0.6371	0.3730		
	2	0.2404	0.7083	0.7480	0.6428	1.5557		0.6663	4.3121
	3	0.0880	0.9675	0.9715	0.1811	5.5205		0.9635	14.8753
7	1	0.2652	0.4344	0.5090	1.0421	0.9596		0.3441	1.0173
	2	0.1835	0.7828	0.8040	0.4565	2.1908		0.7610	7.0443
	3	0.0655	0.9761	0.9783	0.1339	7.4679		0.9739	17.4835
	4	0.2944		0.2944			0.2944		
8	1	0.2543	0.1953	0.3206	1.5862	0.6304	0.2822		
	2	0.2156	0.5561	0.5964	0.7230	1.3832		0.5126	3.4258
	3	0.1441	0.8323	0.8447	0.3412	2.9309		0.8197	9.4683
	4	0.0506	0.9817	0.9830	0.1029	9.7173		0.9804	19.7624
9	1	0.2176	0.3423	0.4056	1.0730	0.9320		0.2642	0.8624
	2	0.1774	0.6433	0.6673	0.5317	1.8808		0.6184	5.8052
	3	0.1158	0.8667	0.8744	0.2649	3.7755		0.8589	11.6163
	4	0.0402	0.9856	0.9864	0.0815	12.2659		0.9848	21.7812
	5	0.2315		0.2315			0.2315		
10	1	0.2065	0.1565	0.2591	1.5940	0.6274	0.2267		
	2	0.1863	0.4543	0.4910	0.7588	1.3178		0.4143	3.0721
	3	0.1478	0.7075	0.7228	0.4090	2.4451		0.6919	7.9515
	4	0.0949	0.8915	0.8965	0.2117	4.7236		0.8864	13.5344
	5	0.0327	0.9883	0.9888	0.0661	15.1199		0.9878	23.5957

Figure 8.29: 0.25 dB Chebyshev Design Table

▣ BASIC LINEAR DESIGN

ORDER	SECTION	REAL PART	IMAGINARY PART	F_0	α	Q	-3 dB FREQUENCY	PEAKING FREQUENCY	PEAKING LEVEL
2	1	0.5129	0.7225	1.2314	1.1577	0.8638		0.7072	0.5002
3	1	0.2683	0.8753	1.0688	0.5861	1.7061		0.9727	5.0301
	2	0.5366		0.6265			0.6265		
4	1	0.3872	0.3850	0.5969	1.4182	0.7051			
	2	0.1605	0.9297	1.0313	0.3402	2.9391	0.5951	1.0010	9.4918
5	1	0.2767	0.5902	0.6905	0.8490	1.1779			
	2	0.1057	0.9550	1.0178	0.2200	4.5451		0.5522	2.2849
	3	0.3420		0.3623			0.3623	1.0054	13.2037
6	1	0.2784	0.2596	0.3963	1.4627	0.6836			
	2	0.2037	0.7091	0.7680	0.5522	1.8109	0.3827	0.7071	5.5025
	3	0.0746	0.9687	1.0114	0.1536	6.5119		1.0055	16.2998
7	1	0.2241	0.4349	0.5040	0.9161	1.0916			
	2	0.1550	0.7836	0.8228	0.3881	2.5767		0.3839	1.7838
	3	0.0553	0.9771	1.0081	0.1130	8.8487		0.7912	8.3880
	4	0.2487		0.2562			0.2562	1.0049	18.9515
8	1	0.2144	0.1955	0.2968	1.4779	0.6767			
	2	0.1817	0.5565	0.5989	0.6208	1.6109	0.2835	0.5381	4.5815
	3	0.1214	0.8328	0.8610	0.2885	3.4662		0.8429	10.8885
	4	0.0426	0.9824	1.0060	0.0867	11.5305		1.0041	21.2452
9	1	0.1831	0.3425	0.3954	0.9429	1.0605			
	2	0.1493	0.6436	0.6727	0.4520	2.2126		0.2947	1.6023
	3	0.0974	0.8671	0.8884	0.2233	4.4779		0.6374	7.1258
	4	0.0338	0.9861	1.0046	0.0686	14.5829		0.8773	13.0759
	5	0.1949		0.1984			0.1984	1.0034	23.2820
10	1	0.1736	0.1566	0.2338	1.4851	0.6734			
	2	0.1566	0.4545	0.4807	0.6515	1.5349	0.2221	0.4267	4.2087
	3	0.1243	0.7078	0.7186	0.3459	2.8907		0.6968	9.3520
	4	0.0798	0.8919	0.8955	0.1782	5.6107		0.8883	15.0149
	5	0.0275	0.9887	0.9891	0.0556	17.9833		0.9883	25.1008

Figure 8.30: 0.5 dB Chebyshev Design Table

**ANALOG FILTERS
STANDARD RESPONSES**

ORDER	SECTION	REAL PART	IMAGINARY PART	F ₀	α	Q	-3 dB FREQUENCY	PEAKING FREQUENCY	PEAKING LEVEL
2	1	0.4508	0.7351	0.8623	1.0456	0.9564		0.5806	0.9995
3	1	0.2257	0.8822	0.9106	0.4957	2.0173		0.8528	6.3708
	2	0.4513		0.4513			0.4513		
4	1	0.3199	0.3868	0.5019	1.2746	0.7845		0.2174	0.1557
	2	0.1325	0.9339	0.9433	0.2809	3.5594		0.9245	11.1142
5	1	0.2265	0.5918	0.6337	0.7149	1.3988		0.5467	3.5089
	2	0.0865	0.9575	0.9614	0.1800	5.5559		0.9536	14.9305
	3	0.2800		0.2800			0.2800		
6	1	0.2268	0.2601	0.3451	1.3144	0.7608		0.1273	0.0813
	2	0.1550	0.7106	0.7273	0.4262	2.3462		0.6935	7.6090
	3	0.0608	0.9707	0.9726	0.1249	8.0036		0.9688	18.0827
7	1	0.1819	0.4354	0.4719	0.7710	1.2971		0.3956	2.9579
	2	0.1259	0.7846	0.7946	0.3169	3.1558		0.7744	10.0927
	3	0.0449	0.9785	0.9795	0.0918	10.8982		0.9775	20.7563
	4	0.2019		0.2019			0.2019		
8	1	0.1737	0.1956	0.2616	1.3280	0.7530		0.0899	0.0611
	2	0.1473	0.5571	0.5762	0.5112	1.9560		0.5373	6.1210
	3	0.0984	0.8337	0.8395	0.2344	4.2657		0.8279	12.6599
	4	0.0346	0.9836	0.9842	0.0702	14.2391		0.9830	23.0750
9	1	0.1482	0.3427	0.3734	0.7938	1.2597		0.3090	2.7498
	2	0.1208	0.6442	0.6554	0.3686	2.7129		0.6328	8.8187
	3	0.0788	0.8679	0.8715	0.1809	5.5268		0.8643	14.8852
	4	0.0274	0.9869	0.9873	0.0555	18.0226		0.9865	25.1197
	5	0.1577		0.1577			0.1577		
10	1	0.1403	0.1567	0.2103	1.3341	0.7496		0.0698	0.0530
	2	0.1266	0.4548	0.4721	0.5363	1.8645		0.4368	5.7354
	3	0.1005	0.7084	0.7155	0.2809	3.5597		0.7012	11.1147
	4	0.0645	0.8926	0.8949	0.1441	6.9374		0.8903	16.8466
	5	0.0222	0.9895	0.9897	0.0449	22.2916		0.9893	26.9650

Figure 8.31: 1 dB Chebyshev Design Table

▣ BASIC LINEAR DESIGN

ORDER	SECTION	REAL PART	IMAGINARY PART	F ₀	α	Q	-3 dB FREQUENCY	PEAKING FREQUENCY	PEAKING LEVEL
2	1	1.1050	0.6368	1.2754	1.7328	0.5771	1.0020		
3	1	1.0509	1.0025	1.4524	1.4471	0.6910	1.4185		
	2	1.3270		1.3270			1.3270		
4	1	1.3596	0.4071	1.4192	1.9160	0.5219	0.9705		
	2	0.9877	1.2476	1.5912	1.2414	0.8055	0.7622	0.2349	
5	1	1.3851	0.7201	1.5611	1.7745	0.5635	1.1876		
	2	0.9606	1.4756	1.7607	1.0911	0.9165		1.1201	0.7768
	3	1.5069		1.5069			1.5069		
6	1	1.5735	0.3213	1.6060	1.9596	0.5103	1.0638		
	2	1.3836	0.9727	1.6913	1.6361	0.6112	1.4323		
	3	0.9318	1.6640	1.9071	0.9772	1.0234		1.3786	1.3851
7	1	1.6130	0.5896	1.7174	1.8784	0.5324	1.2074		
	2	1.3797	1.1923	1.8235	1.5132	0.6608	1.6964		
	3	0.9104	1.8375	2.0507	0.8879	1.1262		1.5961	1.9860
	4	1.6853		1.6853			1.6853		
8	1	1.7627	0.2737	1.7838	1.9763	0.5060	1.1675		
	2	0.8955	2.0044	2.1953	0.8158	1.2258		1.7932	2.5585
	3	1.3780	1.3926	1.9591	1.4067	0.7109		0.2011	0.0005
	4	1.6419	0.8256	1.8378	1.7868	0.5597	1.3849		
9	1	1.8081	0.5126	1.8794	1.9242	0.5197	1.2774		
	2	1.6532	1.0319	1.9488	1.6966	0.5894	1.5747		
	3	1.3683	1.5685	2.0815	1.3148	0.7606		0.7668	0.0807
	4	0.8788	2.1509	2.3235	0.7564	1.3220		1.9632	3.0949
	5	1.8575		1.8575			1.8575		
10	1	1.9335	0.2451	1.9490	1.9841	0.5040	1.2685		
	2	1.8467	0.7335	1.9870	1.8587	0.5380	1.4177		
	3	1.6661	1.2246	2.0678	1.6115	0.6205	1.7848		
	4	1.3648	1.7395	2.2110	1.2346	0.8100		1.0785	0.2531
	5	0.8686	2.2994	2.4580	0.7067	1.4150		2.1291	3.5944

Figure 8.32: Bessel Design Table

**ANALOG FILTERS
STANDARD RESPONSES**

ORDER	SECTION	REAL PART	IMAGINARY PART	F ₀	α	Q	-3 dB FREQUENCY	PEAKING FREQUENCY	PEAKING LEVEL
2	1	1.0087	0.6680	1.2098	1.6675	0.5997	0.9999		
3	1	0.8541	1.0725	1.3710	1.2459	0.8026		0.6487	0.2232
	2	1.0459		1.0459			1.0459		
4	1	0.9648	0.4748	1.0753	1.7945	0.5573	0.8056		
	2	0.7448	1.4008	1.5865	0.9389	1.0650		1.1864	1.6286
5	1	0.8915	0.8733	1.2480	1.4287	0.6999	1.2351		
	2	0.6731	1.7085	1.8363	0.7331	1.3641		1.5703	3.3234
	3	0.9430		0.9430			0.9430		
6	1	0.8904	0.4111	0.9807	1.8158	0.5507	0.7229		
	2	0.8233	1.2179	1.4701	1.1201	0.8928		0.8975	0.6495
	3	0.6152	1.9810	2.0743	0.5932	1.6859		1.8831	4.9365
7	1	0.8425	0.7791	1.1475	1.4684	0.6810	1.1036		
	2	0.7708	1.5351	1.7177	0.8975	1.1143		1.3276	1.9162
	3	0.5727	2.2456	2.3175	0.4942	2.0233		2.1713	6.3948
	4	0.8615		0.8615			0.8615		
8	1	0.8195	0.3711	0.8996	1.8219	0.5489	0.6600		
	2	0.7930	1.1054	1.3604	1.1658	0.8578		0.7701	0.4705
	3	0.7213	1.8134	1.9516	0.7392	1.3528		1.6638	3.2627
	4	0.5341	2.4761	2.5330	0.4217	2.3713		2.4178	7.6973
9	1	0.7853	0.7125	1.0604	1.4812	0.6751	1.0102		
	2	0.7555	1.4127	1.6020	0.9432	1.0602		1.1937	1.6005
	3	0.6849	2.0854	2.1950	0.6241	1.6024		1.9697	4.5404
	4	0.5060	2.7133	2.7601	0.3667	2.7274		2.6657	8.8633
	5	0.7983		0.7983			0.7983		
10	1	0.7592	0.3413	0.8324	1.8241	0.5482	0.6096		
	2	0.7467	1.0195	1.2637	1.1818	0.8462		0.6941	0.4145
	3	0.7159	1.6836	1.8295	0.7826	1.2778		1.5238	2.8507
	4	0.6475	2.3198	2.4085	0.5377	1.8598		2.2276	5.7152
	5	0.4777	2.9128	2.9517	0.3237	3.0895		2.8734	9.9130

Figure 8.33: Linear Phase with Equiripple Error of 0.05° Design Table

▣ BASIC LINEAR DESIGN

ORDER	SECTION	REAL PART	IMAGINARY PART	F ₀	α	Q	-3 dB FREQUENCY	PEAKING FREQUENCY	PEAKING LEVEL
2	1	0.8590	0.6981	1.1069	1.5521	0.6443	1.0000		
3	1	0.6969	1.1318	1.3292	1.0486	0.9536		0.8918	0.9836
	2	0.8257		0.8257			0.8257		
4	1	0.7448	0.5133	0.9045	1.6468	0.6072			
	2	0.6037	1.4983	1.6154	0.7475	1.3379	0.7597	1.3713	3.1817
5	1	0.6775	0.9401	1.1588	1.1693	0.8552		0.6518	0.4579
	2	0.5412	1.8256	1.9041	0.5684	1.7592		1.7435	5.2720
	3	0.7056		0.7056			0.7056		
6	1	0.6519	0.4374	0.7850	1.6608	0.6021	0.6522		
	2	0.6167	1.2963	1.4355	0.8592	1.1639		1.1402	2.2042
	3	0.4893	2.0982	2.1545	0.4542	2.2016		2.0404	7.0848
7	1	0.6190	0.8338	1.0385	1.1922	0.8388		0.5586	0.3798
	2	0.5816	1.6455	1.7453	0.6665	1.5004		1.5393	4.0353
	3	0.4598	2.3994	2.4431	0.3764	2.6567		2.3549	8.6433
	4	0.6283		0.6283			0.6283		
8	1	0.5791	0.3857	0.6958	1.6646	0.6007	0.5764		
	2	0.5665	1.1505	1.2824	0.8835	1.1319		1.0014	2.0187
	3	0.5303	1.8914	1.9643	0.5399	1.8521		1.8155	5.6819
	4	0.4148	2.5780	2.6112	0.3177	3.1475		2.5444	10.0703
9	1	0.5688	0.7595	0.9489	1.1989	0.8341		0.5033	0.3581
	2	0.5545	1.5089	1.6076	0.6899	1.4496		1.4033	3.7748
	3	0.5179	2.2329	2.2922	0.4519	2.2130		2.1720	7.1270
	4	0.4080	2.9028	2.9313	0.2784	3.5923		2.8740	11.1925
	5	0.5728		0.5728			0.5728		
10	1	0.5249	0.3487	0.6302	1.6659	0.6003	0.5215		
	2	0.5193	1.0429	1.1650	0.8915	1.1217		0.9044	1.9598
	3	0.5051	1.7264	1.7988	0.5616	1.7806		1.6509	5.3681
	4	0.4711	2.3850	2.4311	0.3876	2.5802		2.3380	8.3994
	5	0.3708	2.9940	3.0169	0.2458	4.0681		2.9709	12.2539

Figure 8.34: Linear Phase with Equiripple Error of 0.5° Design Table

**ANALOG FILTERS
STANDARD RESPONSES**

ORDER SECTION	REAL PART		IMAGINARY PART		F ₀	α	Q	-3 dB		PEAKING	
	REAL PART	IMAGINARY PART	REAL PART	IMAGINARY PART				FREQUENCY	LEVEL	FREQUENCY	LEVEL
3	1	0.9360	1.2168		1.5352	1.2194	0.8201				
	2	0.9360			0.9360			0.9360		0.7775	0.2956
4	1	0.9278	1.6995		1.9363	0.9583	1.0435				
	2	0.9192	0.5560		1.0743	1.7113	0.5844	0.8582	1.4239		1.5025
5	1	0.8075	0.9973		1.2832	1.2585	0.7946				
	2	0.7153	0.2053		0.7442	1.9224	0.5202	0.5065	0.5853		0.1921
	3	0.8131			0.8131			0.8131			
6	1	0.7019	0.4322		0.8243	1.7030	0.5872	0.6627			
	2	0.6667	1.2931		1.4549	0.9165	1.0911		1.1080		1.7809
	3	0.4479	2.1363		2.1827	0.4104	2.4366		2.0888		7.9227
7	1	0.6155	0.7703		0.9860	1.2485	0.8010			0.4632	0.2168
	2	0.5486	1.5154		1.6116	0.6808	1.4689		1.4126		3.8745
	3	0.2905	2.1486		2.1681	0.2680	3.7318		2.1289		11.5169
	4	0.6291			0.6291			0.6291			
8	1	0.5441	0.3358		0.6394	1.7020	0.5876	0.5145			
	2	0.5175	0.9962		1.1226	0.9220	1.0846		0.8512		1.7432
	3	0.4328	1.6100		1.6672	0.5192	1.9260		1.5507		5.9962
	4	0.1978	2.0703		2.0797	0.1902	5.2571		2.0608		14.4545
9	1	0.4961	0.6192		0.7934	1.2505	0.7997			0.3705	0.2116
	2	0.4568	1.2145		1.2976	0.7041	1.4203		1.1253		3.6221
	3	0.3592	1.7429		1.7795	0.4037	2.4771		1.7055		8.0594
	4	0.1489	2.1003		2.1056	0.1414	7.0704		2.0950		17.0107
	5	0.5065			0.5065			0.5065			
10	1	0.4535	0.2794		0.5327	1.7028	0.5873	0.4283			
	2	0.4352	0.8289		0.9362	0.9297	1.0756		0.7055		1.6904
	3	0.3886	1.3448		1.3998	0.5552	1.8011		1.2874		5.4591
	4	0.2908	1.7837		1.8072	0.3218	3.1074		1.7598		9.9618
	5	0.1136	2.0599		2.0630	0.1101	9.0802		2.0568		19.1751

Figure 8.35: Gaussian to 12 dB Design Table

▣ BASIC LINEAR DESIGN

ORDER	SECTION	REAL		IMAGINARY		F ₀	α	Q	-3 dB		PEAKING	
		PART	PART	PART	PART				FREQUENCY	FREQUENCY	FREQUENCY	LEVEL
3	1	0.9622	1.2214	1.5549	1.2377	0.8080				0.7523		0.2448
	2	0.9776	0.5029	1.0994	1.7785	0.5623			0.8338			
4	1	0.7940	0.5029	0.9399	1.6896	0.5919						
	2	0.6304	1.5407	1.6647	0.7574	1.3203			0.7636		1.4058	3.0859
5	1	0.6190	0.8254	1.0317	1.1999	0.8334						
	2	0.3559	1.5688	1.6087	0.4425	2.2600					0.5460	0.3548
	3	0.6650		0.6650					0.6650		1.5279	7.3001
6	1	0.5433	0.3431	0.6426	1.6910	0.5914			0.5215			
	2	0.4672	0.9991	1.1029	0.8472	1.1804					0.8831	2.2992
	3	0.2204	1.5067	1.5227	0.2895	3.4545					1.4905	10.8596
7	1	0.4580	0.5932	0.7494	1.2223	0.8182						
	2	0.3649	1.1286	1.1861	0.6153	1.6253					0.3770	0.2874
	3	0.1522	1.4938	1.5015	0.2027	4.9328					1.0680	4.6503
	4	0.4828		0.4828					0.4828		1.4860	13.9067
8	1	0.4222	0.2640	0.4979	1.6958	0.5897			0.4026			
	2	0.3833	0.7716	0.8616	0.8898	1.1239					0.6697	1.9722
	3	0.2678	1.2066	1.2360	0.4333	2.3076					1.1765	7.4721
	4	0.1122	1.4798	1.4840	0.1512	6.6134					1.4755	16.4334
9	1	0.3700	0.4704	0.5985	1.2365	0.8088						
	2	0.3230	0.9068	0.9626	0.6711	1.4901					0.2905	0.2480
	3	0.2309	1.2634	1.2843	0.3596	2.7811					0.8473	3.9831
	4	0.0860	1.4740	1.4765	0.1165	8.5804					1.2421	9.0271
	5	0.3842		0.3842					0.3842		1.4715	18.6849
10	1	0.3384	0.2101	0.3983	1.6991	0.5885			0.3212			
	2	0.3164	0.6180	0.6943	0.9114	1.0972					0.5309	1.8164
	3	0.2677	0.9852	1.0209	0.5244	1.9068					0.9481	5.9157
	4	0.1849	1.2745	1.2878	0.2871	3.4825					1.2610	10.9284
	5	0.0671	1.4389	1.4405	0.0931	10.7401					1.4373	20.6296

Figure 8.36: Gaussian to 6 dB Design Table